

# iZero 2

*User Manual*

ENG



This manual contains the instructions for the installation and use of:

**Selea iZero 2** in all its possible variations.

This manual is only included for information purposes and its content may be changed without prior notice.

In case of disputes, the original language of the manual is Italian. **Selea** is not liable for any translation/interpretation errors.

**Selea** pays the utmost maximum attention to the information provided. However, no guarantee can be given on the content of this manual. The company also specifically rejects any guarantees regarding the saleability of the product, or its suitability for specific purposes.

#### ***Copyrights***

All rights reserved. No part of this manual may be reproduced, forwarded or copied in any shape or form without the specific written consent of Selea.

**Selea** and **iZero 2** are registered trademarks owned by **Selea**.

Microsoft, Windows, Hyperterminal, and Explorer are registered trademarks owned by Microsoft Corporation.

Java and all Java based trademarks are registered trademarks owned by Sun microsystem.

All other product trademarks mentioned in the documentation are only used for identification purposes, and are the property of the respective owners.

#### ***Legal considerations***

Video surveillance may be forbidden by local laws. Before carrying out video surveillance activities, check the legal requirements for the country of installation of the camera.





## WARNINGS

### INTRODUCTION

Thank you for choosing our product.

Our company specialises in the design, development and production of vehicle number plate recognition cameras and software.

The camera discussed in this manual is a very sophisticated product, carefully designed and built to ensure the best performance levels.

This manual contains detailed instructions for the installation and the use of the product.

**To ensure the best possible results, CAREFULLY READ THIS MANUAL BEFORE USING THE PRODUCT and store it with care in a safe place for future consultation.**

**NOTE:** Some images in this document are only included for indicative purposes and may not provide a faithful representation of the actual product components.

### WARNINGS FOR THE INSTALLER AND THE USER

This manual is an integral part of the product. It must be read in full before installing or using the product. Make sure that it is always with the product. If the product is transferred to a new location or sold/transferred to a new owner, always make sure that it is accompanied by this manual, so that it can be read by the new user, installer or any other authorised individuals.

Installation, use, cleaning or maintenance activities not consistent with the instructions of this manual are considered as improper and could cause damage, injury or even death, and will immediately make the warranty null and void, relieving **Selea** of all responsibility.



Extraordinary maintenance activities must **only be carried out by qualified personnel, authorised by the Distributor or Manufacturer.**



During the whole life of the product, product safety or automatic adjustment components may only be modified by the manufacturer or the supplier.



In case of camera malfunctioning, or functional or structural fault, disconnect the camera from the power supply and contact an approved **technical support centre authorised by the Distributor or Manufacturer.** Never attempt to repair the camera yourself. In case of repairs, always ask for original spare parts to be used, to prevent further problems and to ensure compliance with the terms of the warranty.



All tampering or any replacements not carried out by qualified personnel may be dangerous for the user and will immediately relieve the manufacturer from all civil or criminal responsibility.



When received, the product must be checked for integrity as vibrations and shock during transport can cause the loosening of some components. Check the camera enclosure and the product components for any damage. In case of damage, inform the installer and/or our technical support service.



This product is suitable for use by children 8 years old or over, by people with impaired physical, sensory or mental abilities, or by people without experience or knowledge, provided that they are appropriately supervised, or that they have been correctly trained on the safe use of the product, and are aware of the connected hazards.



















The packaging material is potentially dangerous and therefore must be kept away from the reach of children or pets, and disposed of in accordance with local regulations.



In case of enclosure or front glass damage, immediately switch off the camera and send it to a **technical support centre authorised by the Manufacturer or Dealer** for the necessary repairs.



During installation and normal use do not place any objects on the camera, as excessive weight could impair performance.

-  During the installation make sure to handle the product with care, avoiding collision with nearby objects.
-  During the installation the operator must wear all the necessary personal protective equipment as provided for by local legislation. If working in a construction site, it must be ensured that the operator is made aware of all the safety requirements by the appropriate safety personnel.
-  When connecting the product to the electricity network, make sure that all the safety measures are implemented, or seek the assistance of a qualified electrician.
-  We recommend the application of appropriate safety measures to reduce the risk of electric shock and lightning strikes. Carefully read all the instructions in this document.
-  Place or install the product on a stable base and in a protected area, so that it is not possible to step on or trip over power cables, LAN cables or any other connection to the camera.
-  It is recommended that an easily accessible disconnecter switch is installed upstream the camera, in accordance with the legislation in force in the country of installation. This disconnecter switch must have contact separation for all the poles, to ensure complete disconnection in case of overvoltage. Correct connection to the earth is also a mandatory requirement. Under no circumstances should the earth cable be interrupted by the safety switch.
-  For the connection to the power supply, use a double insulation flexible 12V bipolar cable with a minimum section of 1 mm<sup>2</sup>. Alternatively, the camera can also be powered via an Ethernet cable connected to a PoE+ router.
-  Product for outdoor installations. Comply with the temperature range indicated in the manual. Do not touch the ends of connectors and mains cables. All damaged or worn cables must be replaced. In case of product malfunction, to resolve the problem, contact exclusively qualified personnel.
-  Do not install the product during a storm, in high humidity conditions, or when wet.
-  Do not touch the ends of connectors and mains cables. All damaged or worn cables must be replaced immediately.
-  The cables used to connect the camera must not consists of several joined cut lengths, but rather only one single length going from the product to the electric cabinet.
-  Never remove the camera optical assembly.
-  Before carrying out any maintenance or cleaning activities, disconnect the electric power supply.
-  During cleaning activities only use a damp cloth. Do not use solvents or abrasive and non-abrasive products that could damage surfaces or components.
-  If planning not to use the camera for an extended period of time, switch off the general power supply switch upstream the same.
-  **Warning!** The laboratory tests for the definition of the retinal risk level completed on the beam, carried out in compliance with IEC62471:2006 1st. Ed. and EN62471:2008, **show that the beam can be classed as belonging to the NO HAZARD Group**. It is however recommended to avoid looking directly at the illuminator when on. Exposure to infrared rays could cause serious eye damage, particularly for people wearing glasses.

**The company rejects all responsibility for any direct or indirect damage to people, pets or property due to failure to follow all the instructions of this manual, particularly in connection with installation, use and maintenance precautions.**

## PRODUCT DISPOSAL

Pursuant to art. 13 of Italian Legislative Decree no. 49 of 2014 (“Implementation of the WEEE 2012/19/EU directive on Waste Electrical and Electronic Equipment”)



The crossed bin symbol indicates that the product was put on the market after 13 August 2005, and that at the end of its useful life it should be disposed separately from other waste.

The product must also be made unusable by removing the power supply cable.

At the end of its life this product must be disposed of with care, in order to reduce its impact on the environment and improve efficiency in the use of resources, and implementing the “polluter pays”; prevention, preparation for reuse, recycling and recovery principles. Illegal dumping or incorrect disposal of the product will result in the application of fines in accordance with current laws.

### Information on disposal in Italy

In Italy, WEEE must be handed over:

- to Waste Collection Sites
- to the dealer from where a new replacement item is purchased, who is legally required to take the old product free of charge (one item collected for each item sold);

### Information on disposal in EU countries

The WEEE EU regulation has been incorporated in the various countries in different ways. Therefore, you should contact your local authorities or dealer in order to ascertain the correct disposal method.



## RESPECT FOR THE ENVIRONMENT

In developing its products, **Selea** dedicates a lot of resources to environmental aspects. All our products pursue the objectives set in the environmental management system policy developed by the company in compliance with current laws.





This product does not contain dangerous materials, like **CFC**, **HCFC** or **asbestos**.

The packaging is made of **RECYCLABLE MATERIALS**.



**The individual elements must be disposed of in accordance with the regulations of the country of use of the product.**

For the identification of the materials refer to the following table:

| Description           | Material                             |   |
|-----------------------|--------------------------------------|---|
| <b>Pallet</b>         | Wood<br>(FOR)                        |  |
| <b>Packaging box</b>  | Corrugated cardboard<br>(PAP)        |  |
| <b>Protection bag</b> | High density polyethylene<br>(PE-HD) |  |
| <b>Adhesive pads</b>  | Low density polyethylene<br>(PE-LD)  |  |
| <b>Bubble wrap</b>    |                                      |   |

# INDEX

|  |               |
|--|---------------|
| <b>WARNINGS</b> .....                          | <b>3</b>      |
| INTRODUCTION.....                              | 3             |
| WARNINGS FOR THE INSTALLER AND THE USER .....  | 3             |
| PRODUCT DISPOSAL .....                         | 5             |
| RESPECT FOR THE ENVIRONMENT.....               | 5             |
| <br><b>INDEX</b> .....                         | <br><b>6</b>  |
| <br><b>PRODUCT PRESENTATION</b> .....          | <br><b>8</b>  |
| PRODUCT DESCRIPTION .....                      | 8             |
| <br><b>INSTALLATION</b> .....                  | <br><b>10</b> |
| PACKAGE CONTENT.....                           | 10            |
| WARNINGS FOR THE INSTALLER.....                | 10            |
| CAMERA INSTALLATION AND ADJUSTMENT.....        | 12            |
| CAMERA CONNECTION .....                        | 16            |
| ELECTRIC AND LAN NETWORK CONNECTIONS.....      | 16            |
| RECOMMENDATIONS FOR BETTER INSTALLATION.....   | 18            |
| <br><b>USING THE CAMERA</b> .....              | <br><b>20</b> |
| FIRST START-UP.....                            | 20            |
| ACCESSING THE CAMERA FROM THE WEB.....         | 21            |
| LIVE MENU .....                                | 22            |
| MEMORY MENU .....                              | 24            |
| SETUP MENU .....                               | 25            |
| SYSTEM.....                                    | 25            |
| Information.....                               | 25            |
| Clock.....                                     | 25            |
| GPS coordinates.....                           | 26            |
| Licence Management.....                        | 26            |
| NETWORK .....                                  | 27            |
| General.....                                   | 27            |
| Advanced - DNS.....                            | 27            |
| Advanced - Certificates .....                  | 28            |
| Advanced-Network Communication Parameters..... | 28            |
| NUMBER PLATE READING.....                      | 29            |
| General.....                                   | 29            |
| Display .....                                  | 31            |
| Exposure .....                                 | 31            |
| Illuminator .....                              | 32            |
| Context camera .....                           | 32            |
| Processing area .....                          | 33            |
| Country .....                                  | 34            |

|   |           |
|---|-----------|
| CPS34                                       |           |
| Record viewing service.....                 | 34        |
| IMAGE CONTROL.....                          | 35        |
| OSD.....                                    | 35        |
| Privacy.....                                | 35        |
| COMPRESSION PARAMETERS.....                 | 36        |
| Video.....                                  | 36        |
| SECURITY.....                               | 37        |
| General.....                                | 37        |
| Users.....                                  | 37        |
| Encryption.....                             | 37        |
| EVENT MANAGEMENT.....                       | 38        |
| Number plate control list.....              | 38        |
| FTP list synchronisation.....               | 39        |
| Integrated I/O.....                         | 39        |
| Software button.....                        | 40        |
| SENSORS.....                                | 40        |
| General.....                                | 40        |
| NOTIFICATION SERVICES.....                  | 41        |
| General.....                                | 41        |
| Email.....                                  | 41        |
| FTP.....                                    | 41        |
| IP notification.....                        | 42        |
| POS/IP notification.....                    | 43        |
| MEMORY.....                                 | 44        |
| General.....                                | 44        |
| Delete.....                                 | 44        |
| Tools.....                                  | 44        |
| STATUS.....                                 | 45        |
| General.....                                | 45        |
| Tools.....                                  | 45        |
| Logs.....                                   | 45        |
| <b>FIRMWARE UPDATE USING SELEATOOL.....</b> | <b>46</b> |
| <b>CLEANING THE CAMERA.....</b>             | <b>47</b> |
| <b>MAINTENANCE.....</b>                     | <b>47</b> |
| <b>DECLARATION OF CONFORMITY.....</b>       | <b>48</b> |
| <b>NOTES BY THE INSTALLER.....</b>          | <b>49</b> |

# PRODUCT PRESENTATION

## PRODUCT DESCRIPTION

**iZero 2** is a number plate reading column that contains an **ANPR (Automatic Number Plate Recognition)** camera with built-in **OCR**. The refined design also makes it ideal for prestigious structures such as hotels, holiday villages, villas, historic architecture. Easy to install, configure and integrate, in addition to an affordable price, **iZero 2** has high performance in terms of reading precision. **iZero 2** has serial interfaces for integration with the most well-known access control systems (Siemens, Honeywell, HID etc.).

**iZero 2** is available in the following versions:

- = standard (built-in)
- = optional (on request)

| OCR built-in sensor<br>FF = fixed focus             | Column<br>6mm - (M12) FF |
|---|--------------------------|
| MicroSD internal memory for backup and whitelisting | ●                        |
| RS232-485 interface                                 | ●                        |
| Wiegand interface                                   | ●                        |
| OSDP (Siemens) interface                            | ●                        |
| PoE supply  | ●                        |
| 12 VDC supply                                       | ●                        |

It includes a camera with infrared sensitive optical sensor and a **LED IR** illuminator that allow to take a clear photo of a car number plate in any ambient lighting conditions, both day and night, at a distance between **1.5** and **6 metres**. The camera has a **2.3 megapixel** Global Shutter CMOS number plate reading **OCR sensor** with a frame rate of **54 Fps**, B/W equipped with a **6 mm** fixed lens and an **M12** mount.

**OCR** algorithm integrated directly on the camera which can read the plates automatically (free flow) that is without the aid of external synchronism devices. It is important to remember that the reading of the characters of **Selea** cameras are not based, like other systems, on the fallacious motion detection system. Number plate reading is guaranteed even when the vehicle is completely stationary (0 Km/h = no motion detection).

**iZero 2** is a fully IP device capable of connecting to the network through the built-in Ethernet interface. It supports TCP and RTP connection protocols and can compress to JPEG, MPEG4, H264 and H265 formats any video streams produced by the integrated sensor/s, or by an external analogue or IP source connected to **iZero 2**. The video streams, the configuration parameters and the data acquired by the camera can be accessed through the network using an HTTP browser, CPSExplorer QT, Selea video surveillance software programs, or third party software.

**iZero 2** can manage an advanced and flexible set of events and actions using both internal software tools, such as number plate reading or Motion Detection HW, and I/O digital ports, which allow to install an intelligent video surveillance system that does not require additional processing units, therefore saving on wiring and auxiliary components.

The **MicroSD** board allows to have a memory card directly connected to the camera, and use it to store lists of known number plates for comparison with the captured ones, and therefore carry out independent activities based on the results of such comparisons (such as the opening of automatisms, etc.), or as a backup for possible temporary connectivity losses, by storing all the captured number plates until network channel functionality is re-established.

The access to all the camera data and configuration screens can be password protected using credentials issued by the administrator. It is also possible to implement a sophisticated encryption algorithm when transferring data, so that they may not be read by unauthorised clients.

**iZero 2** ensures excellent protection of the privacy and all the information transferred by the camera.

The following pages offer a simple representation of some camera functions:

1. The screenshot gives a representation of the internal vision software through a browser window, showing a real-time **"LIVE"** image of the area covered by the camera.
2. When a vehicle goes through the area, the number plate is framed, captured and stored in the camera memory.
3. All the camera captures are available in the **"MEMORY"** section of the internal software. The data are stored in folders showing the acquisition date, split into sub-folders showing the 24 hour time bands.
4. The data can be forwarded to a remote server.
5. Depending on the reasons for the captures, the server combining the data with those sent may behave differently. For example, if the camera is installed to regulate car park access, when a number plate is recognised and accepted



by the server, the vehicle will be allowed to enter or exit. Otherwise, permission to go through the monitored area will be denied. The data may also be controlled in real time by an operator, who will then be able to grant or deny access. Another possible use is the monitoring of the captured number plates by control authorities, who will be able to connect to remote databases (Transport or Home Offices) to ascertain breaches or irregularities.

1

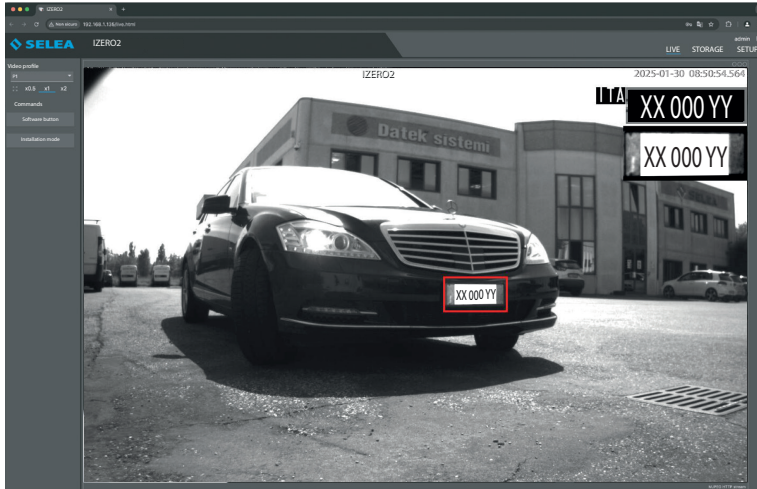

2

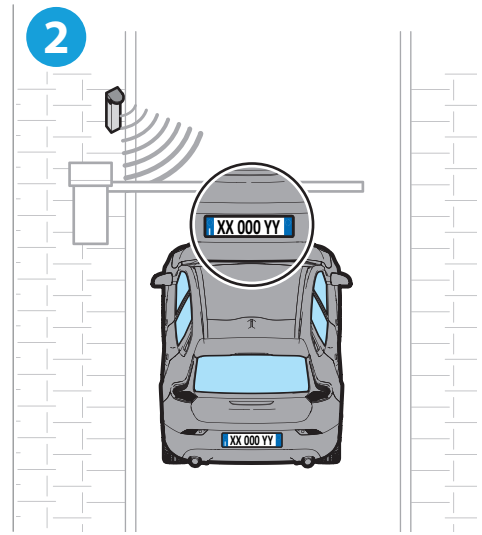

3

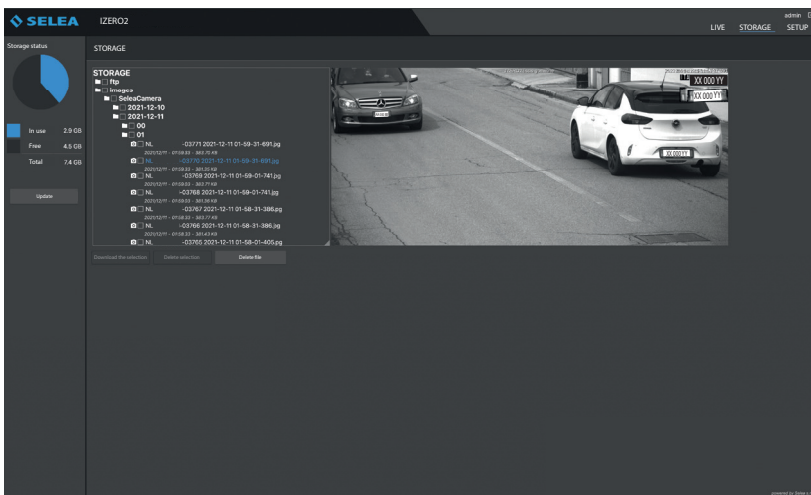

4

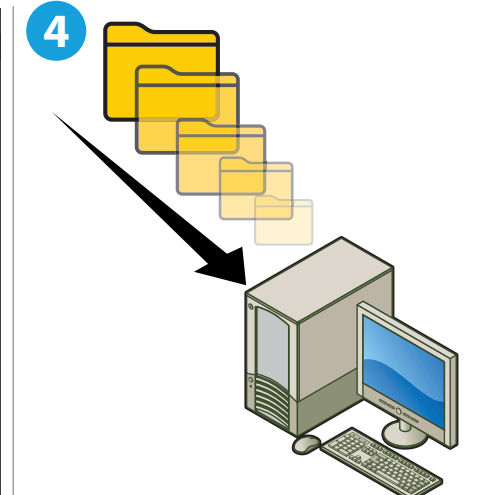

5

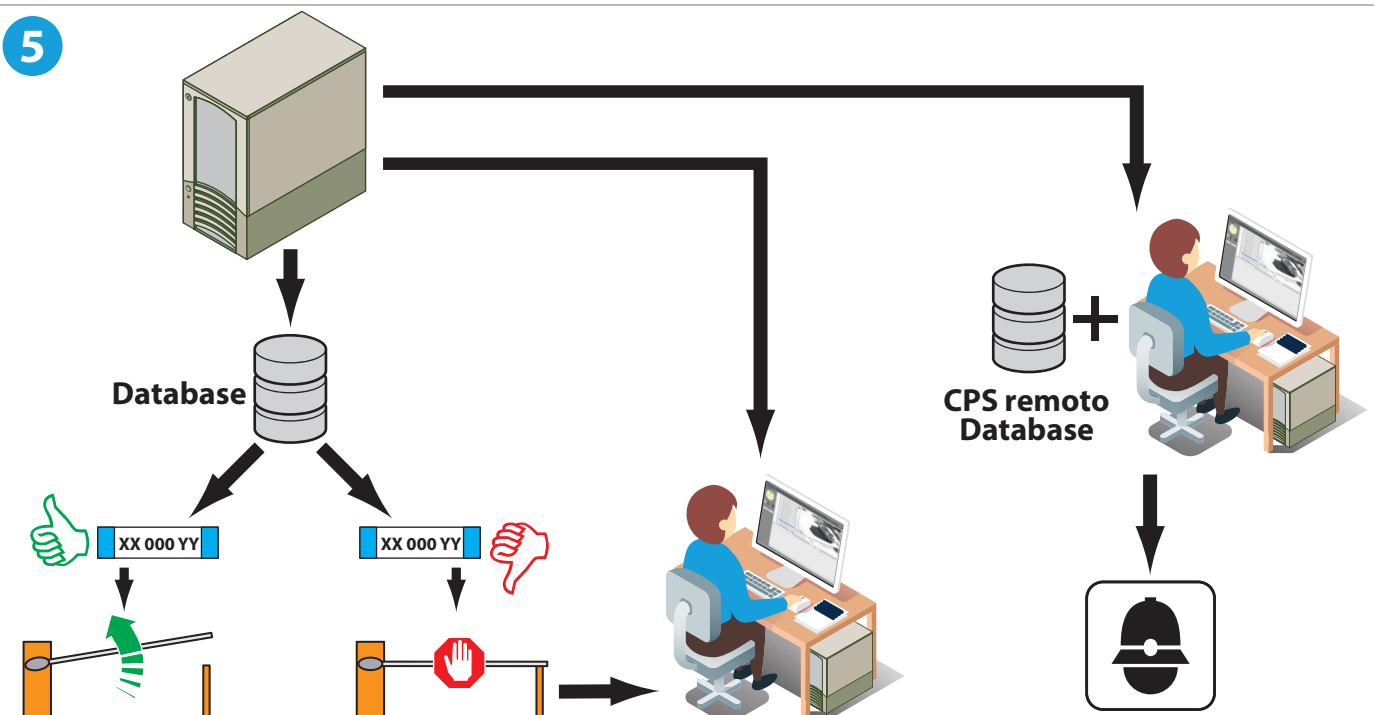

# INSTALLATION

## PACKAGE CONTENT

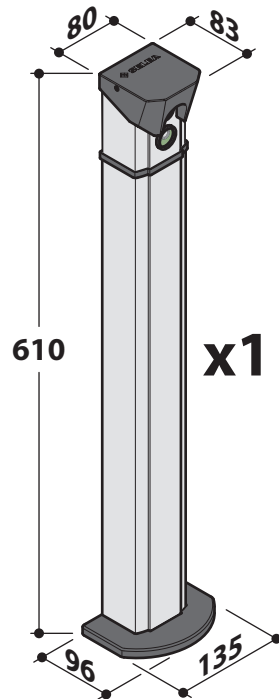

The package includes just one camera and no components for connection to various networks.

## WARNINGS FOR THE INSTALLER

When connecting the product to the electricity network, make sure that all the safety measures are implemented, or seek the assistance of a qualified electrician.



**Do not install the product:**

1. during a storm
2. in high humidity conditions
3. when wet.

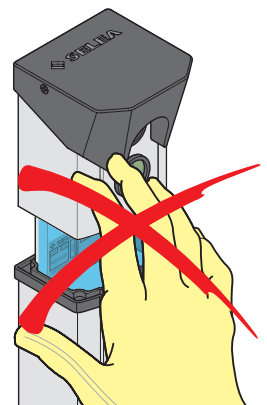
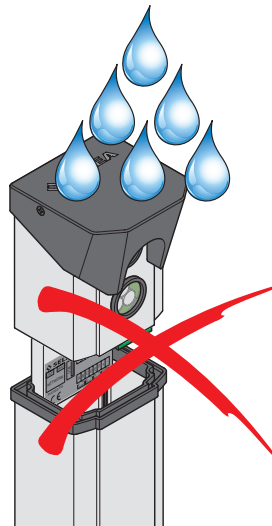
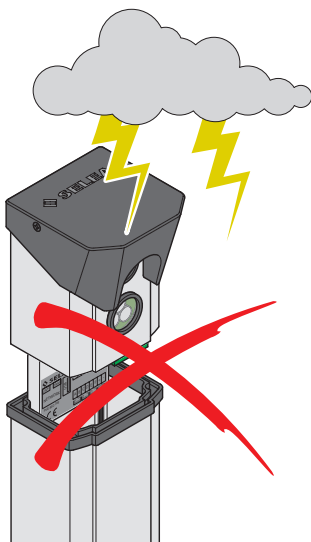



The camera is suitable for both outdoor and indoor installation.

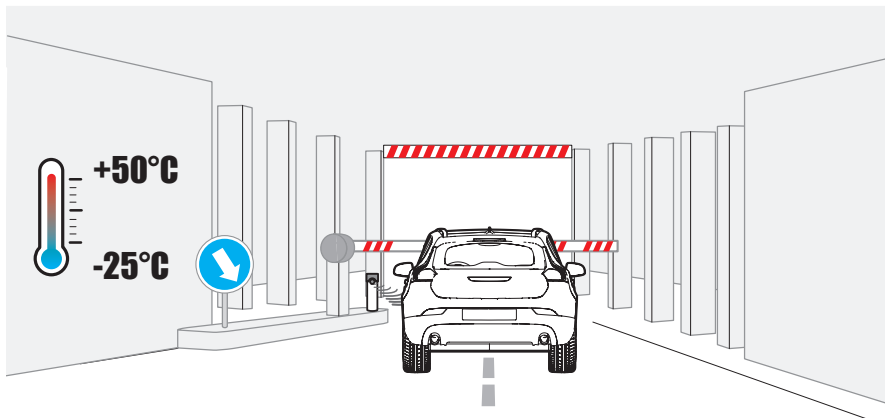
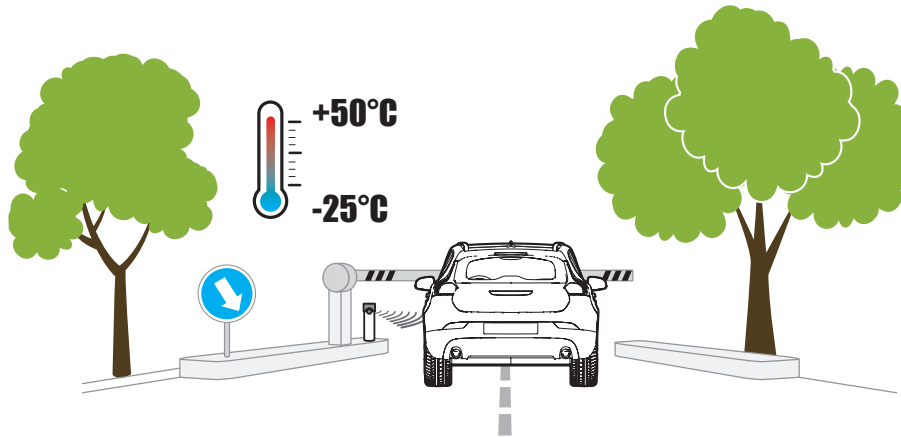

Do not touch the ends of connectors and mains cables.

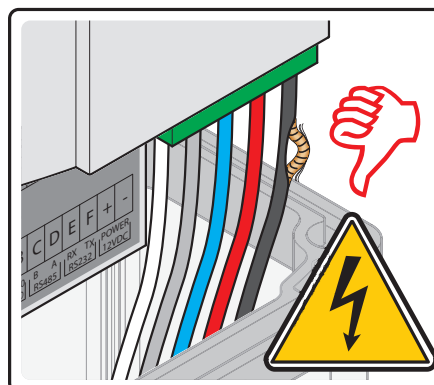
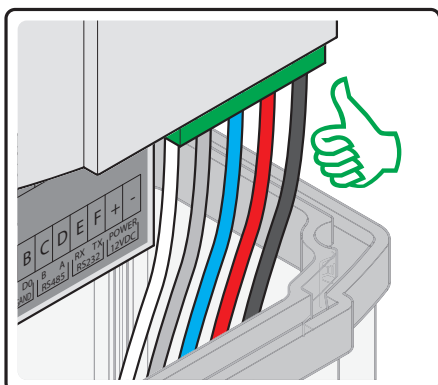
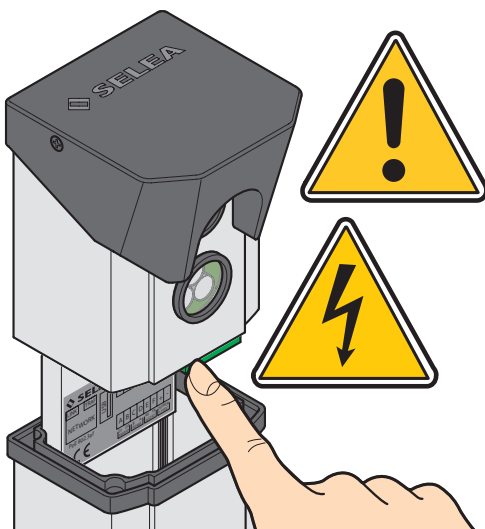

All damaged or worn cables must be replaced immediately.

In case of fault, see the troubleshooting section.

For technical support contact qualified personnel and/or **Selea** directly.

## CAMERA INSTALLATION AND ADJUSTMENT

*iZero 2* must be installed on a fixed surface. In order to make the installation easier, a "support" function may be activated from the camera menu, which will help to keep within the set camera tilt adjustment and character height.

The camera does not need focus adjustment.

### Installation side

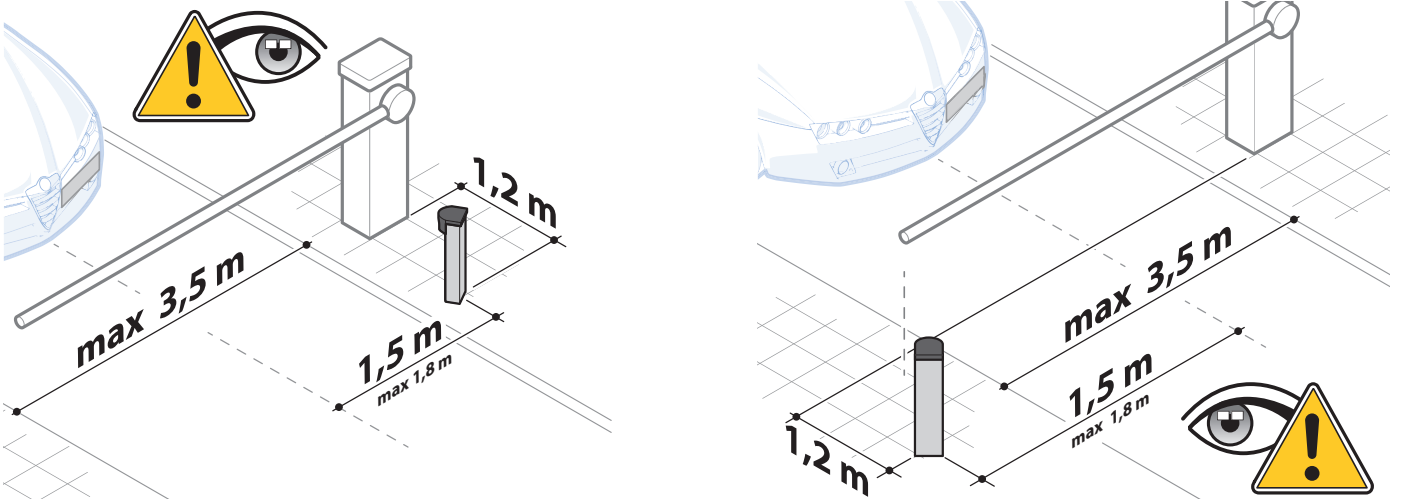

### Vertical capture angle

Also make sure that the number plates are not captured at angles exceeding:

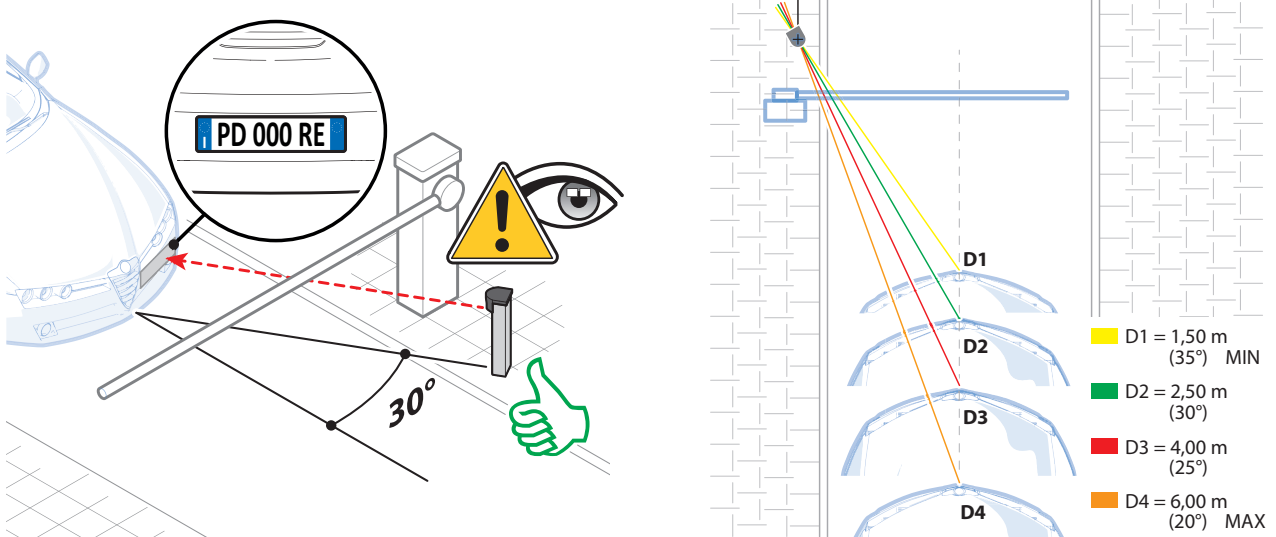

### Detection distance

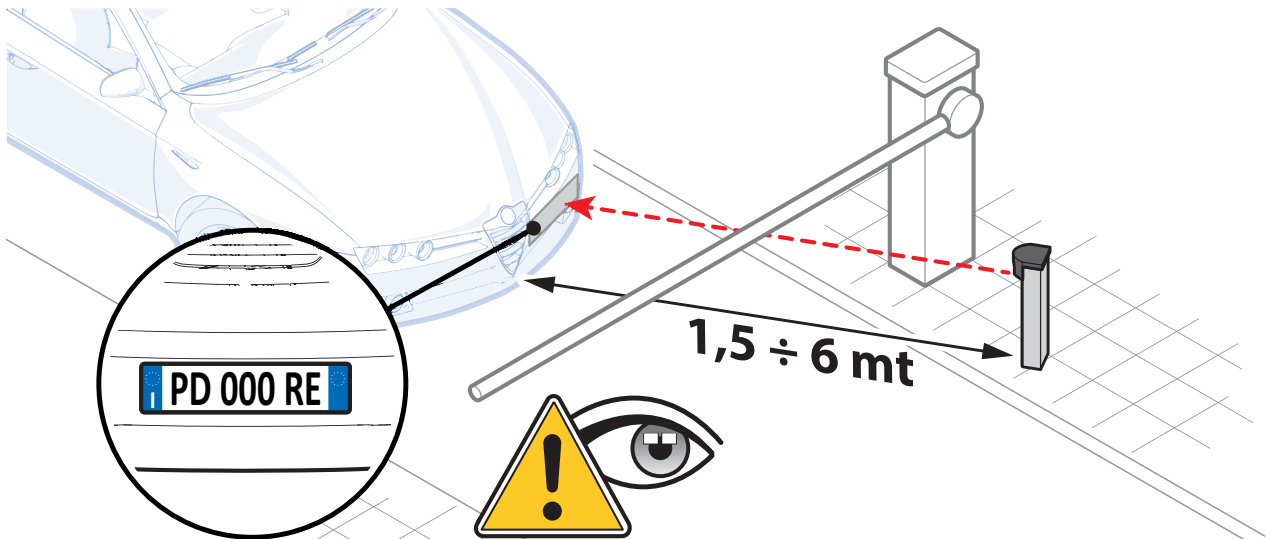

Make sure that the selected installation position actually allows to capture the information from transiting vehicles whilst keeping within the optimum values recommended by **Selea**. We recommended that preliminary capture tests are carried out from the selected position.

### Opening the camera

Remove the cover of the fixing bracket, unscrew the two rear screws and lift the front part of the column.

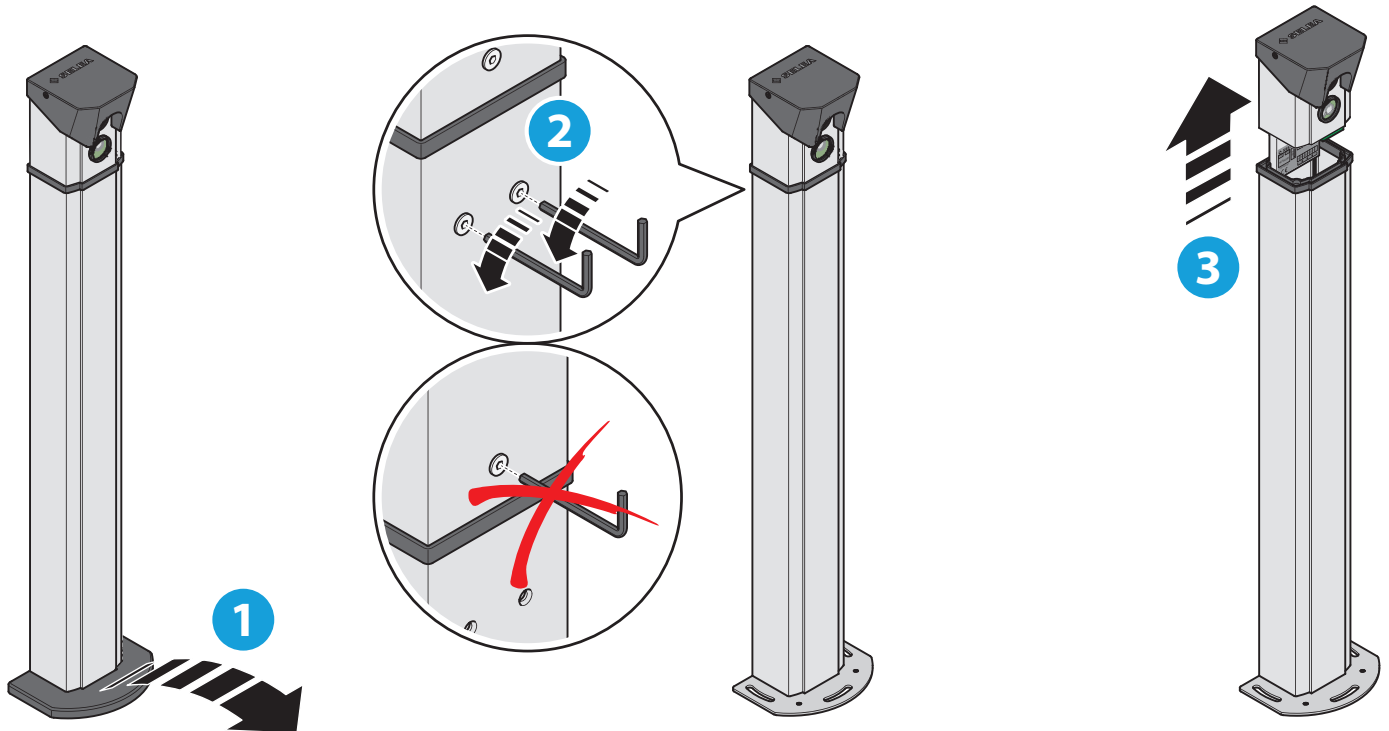

### Pre-installation

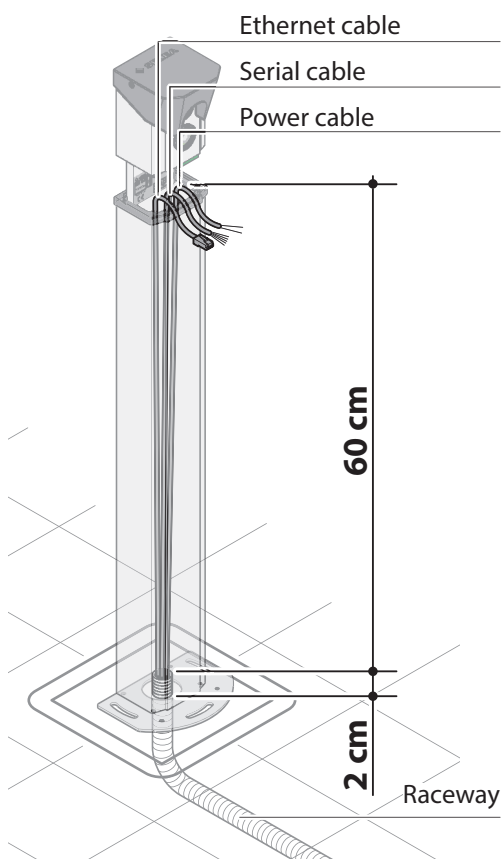

The first operation to do is laying the cables (power supply, serial communication cable, relay and Ethernet network cable) necessary for the operation and integration with the rest of the system.

You must have prepared a flat pit and, inside, an underground raceway. The raceway must protrude no more than 2 cm from the floor.

The cables that come out of the raceway must have a length equal to the height of the column, therefore at least 60 cm long.

### Floor installation

Pass the cables inside the camera and block them using the appropriate sponge inside.

Drill the floor with a drill through the four holes in the bracket.

Before finally fixing the camera to the ground, you must check that the orientation of the lens points in the best reading direction.

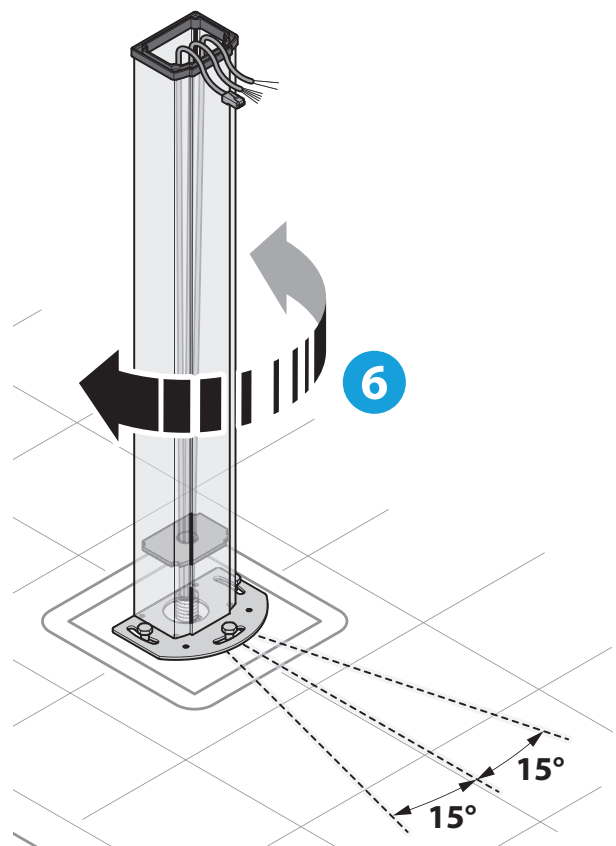
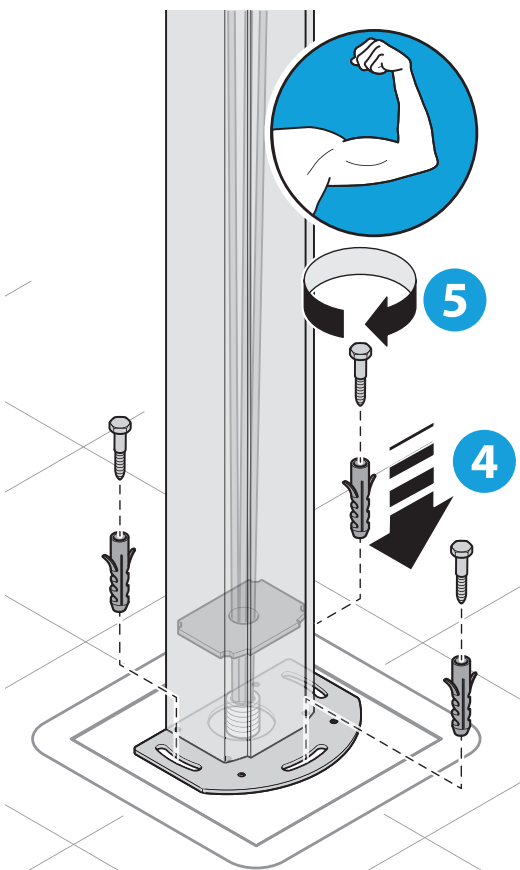
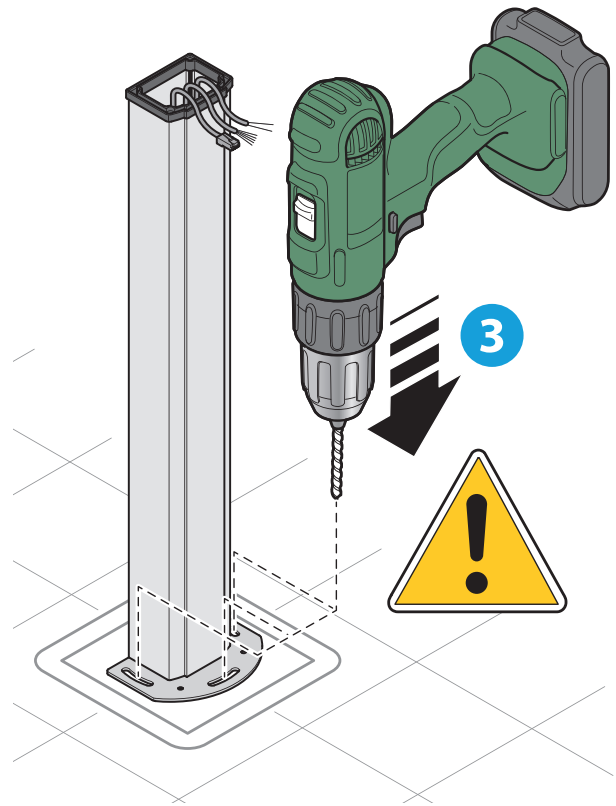
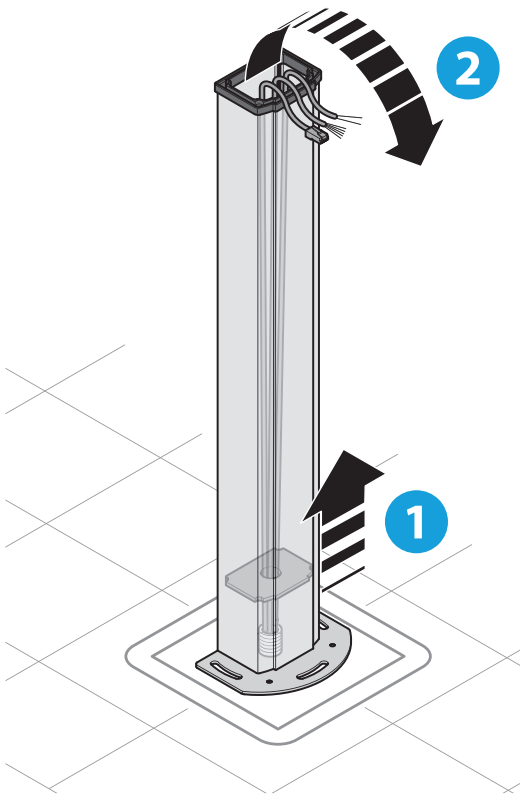

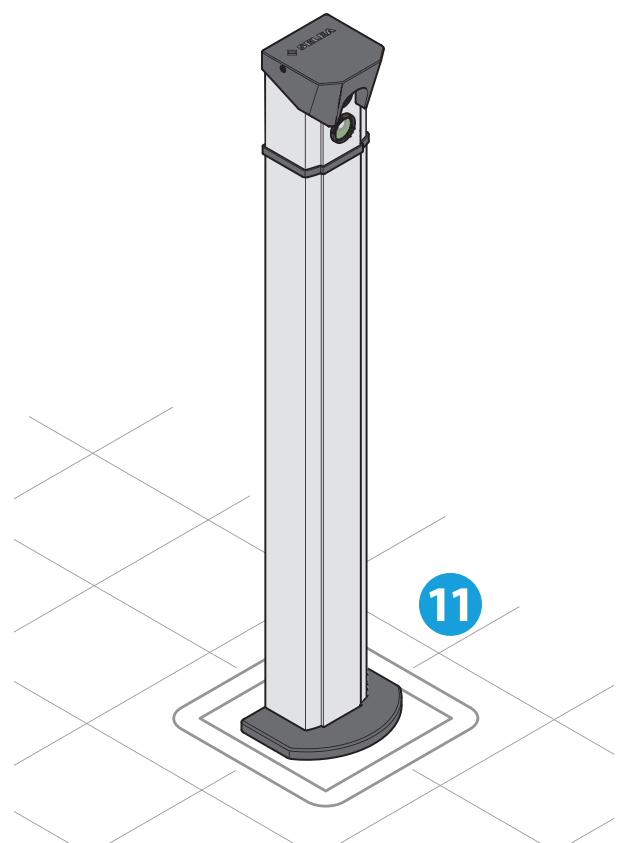
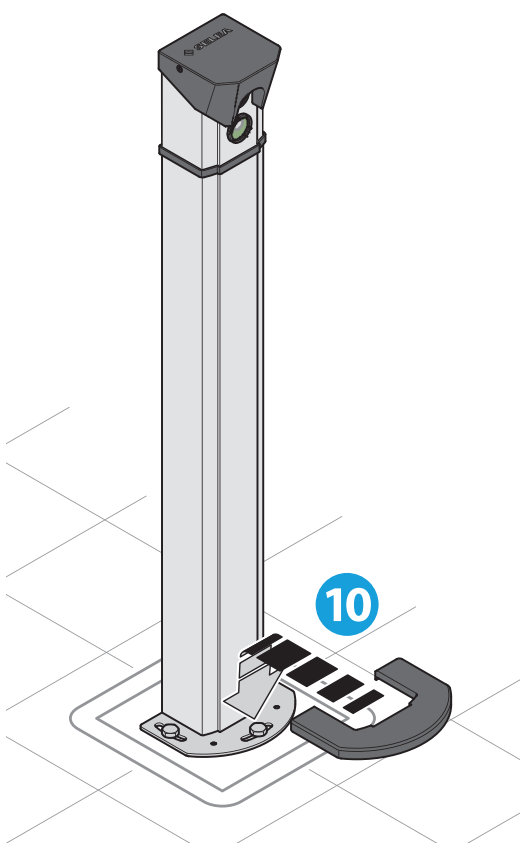
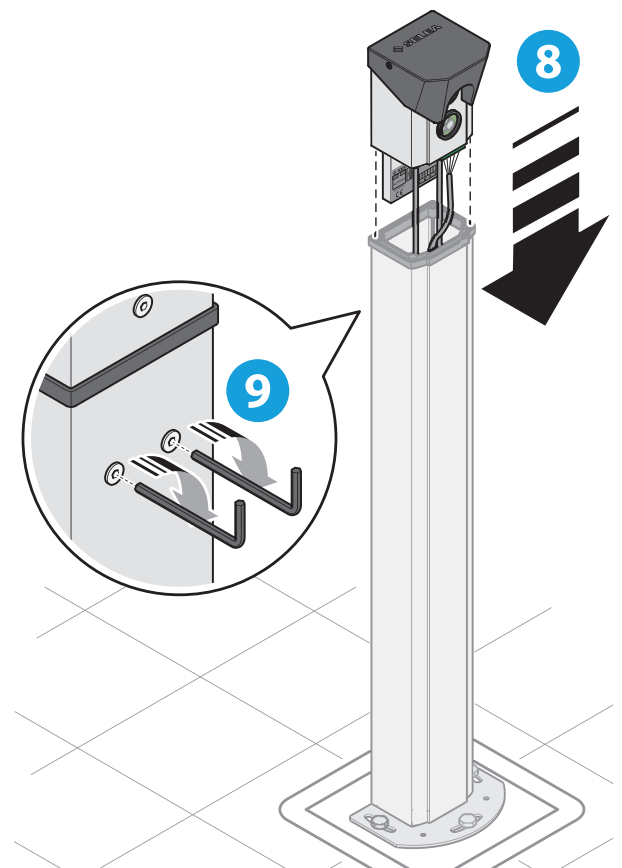
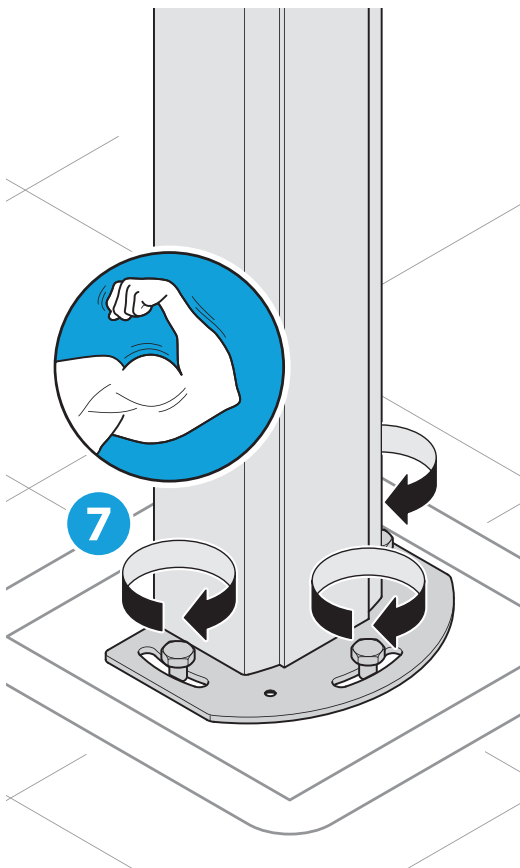

## CAMERA CONNECTION

On the back of the cameras are several ports for different connections.

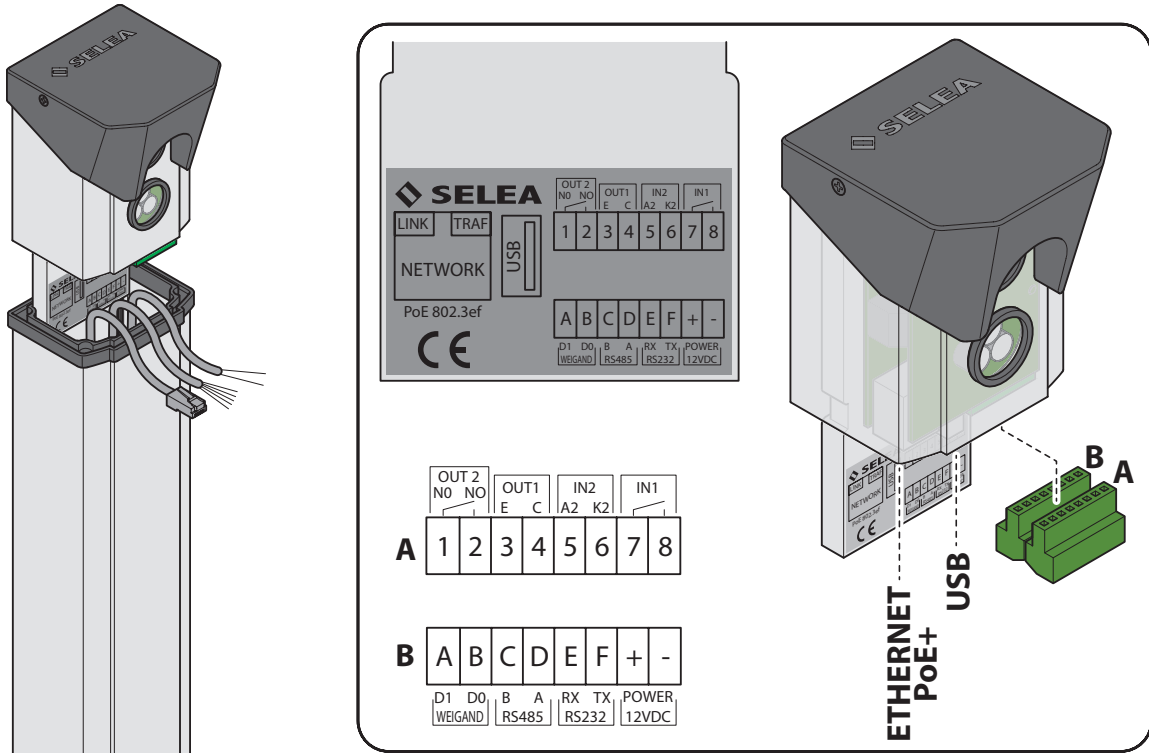

**NETWORK:** 10/100/1000Mb autosensing Ethernet network port.

**A:** connector for the connection of input and output signals.

**B:** connector for *Wiegand*, *RS485* or *RS232* connection and power supply.

**Attention:** *Wiegand*, *RS485* and *RS232* protocols can only be activated individually and cannot be used simultaneously.

**MICRO SD:** on the right side of the board is the 8 GB SLC *microSD* memory card slot (pre-installed).

**USB:** port for the connection of various accessories.

## ELECTRIC AND LAN NETWORK CONNECTIONS

The electric and LAN network connections require the opening of the top of the camera.

The camera can be powered via an **Ethernet** network cable connected to a **PoE+** switch, or via a **12 V** connection via the appropriate terminal.

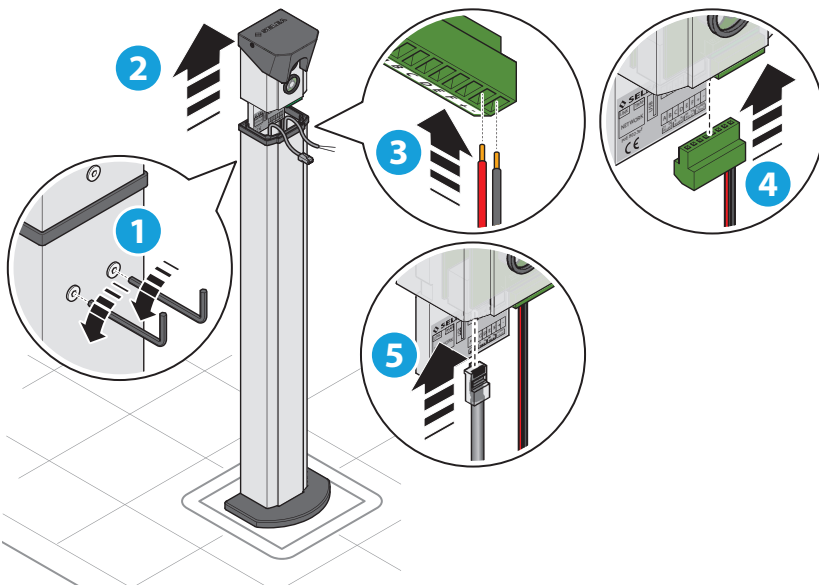

For the **12V** connection, proceed as follows.

1. Unscrew the rear screws.
2. Lift the top.
3. Connect the power cable to the appropriate terminal.
4. Connect the terminal in its housing.
5. Connect the **Ethernet** cable for data connection. In this case, the other end of the cable can be connected to a normal network switch port.
6. Close the camera.

If you want to power the camera only using the **Ethernet** cable, proceed as shown in the figures below

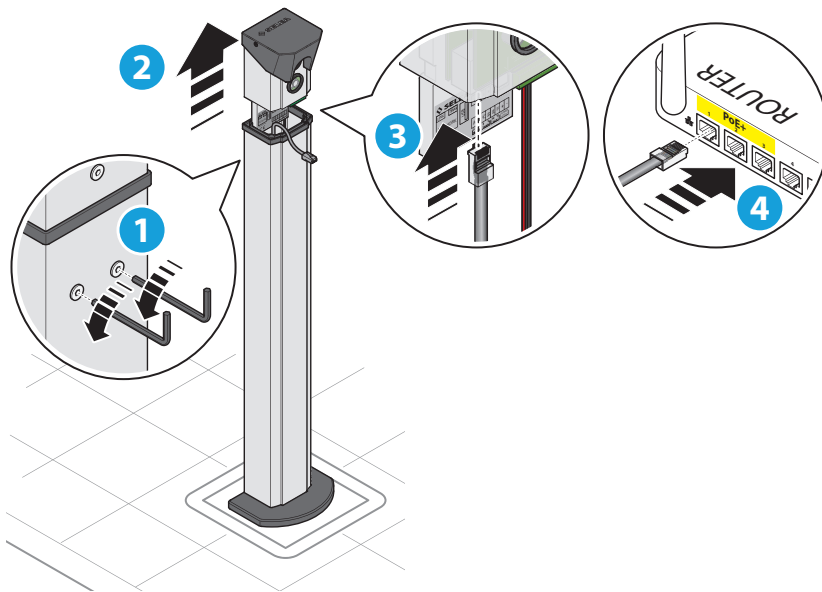

1. Unscrew the rear screws.
2. Lift the top.
3. Insert the male connector of the **RJ45 Ethernet** network cable into the appropriate female connector located on the camera's electrical board. The other end of the cable must be connected to a network switch with a **PoE+** output port.
4. Close the camera.



*We recommend the screws are screwed on the profile using an electric screwdriver so that there are no screws screwed in with different forces from each other. In the upper part there is also a water seal and if the screws were fixed with different forces, infiltrations might occur.*



*Inside the camera enclosure are some connections between the printed board and the camera body: do not tamper with them or use any connections other than those described in these pages.*

## RECOMMENDATIONS FOR BETTER INSTALLATION

The following suggestions have been compiled based on feedback from our installers, who have experienced issues similar to those that you may experience. Following these suggestions can make calibration much easier, helping you to obtain the best from your camera.

Avoid as much as possible to install the camera with the sun at the back: sun light could reflect on the number plate, causing flare that could make it unreadable.

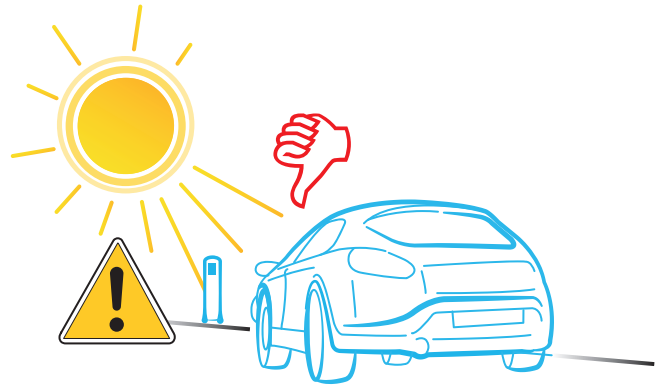

Avoid as much as possible uneven shadows (e.g. trees, gates, poles, signs) only affecting part of the number plate (shadows affecting the whole number plate will not cause reading problems).

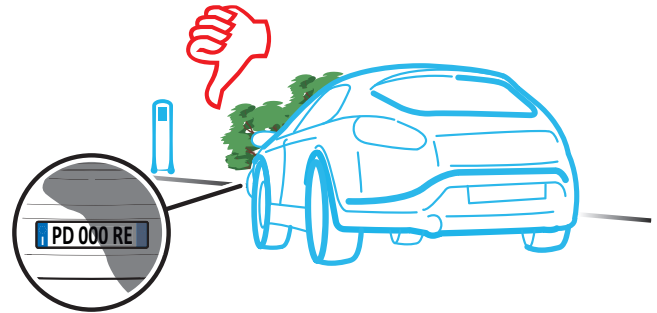

Avoid gates, fencing, irregular pavements (for example cobblestones) in the frame: the interference caused could make it difficult to identify the number plates, making their reading frequency difficult.



Adjust the sun shield so that when the sun is in front of the camera there is no interference with the image.

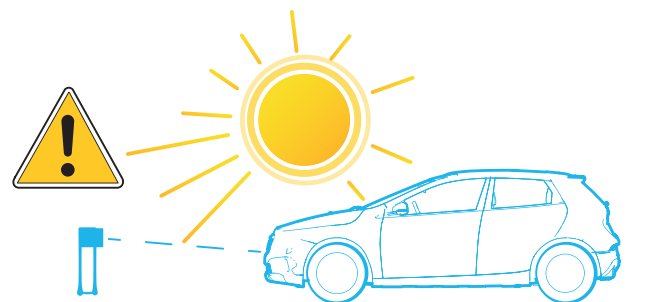



In case of accesses requiring front number plate reading, channel the vehicles and capture number plates when vehicles are still. Avoid positioning the camera much before the gate so that the number plate is captured while the vehicle is moving, allowing the gate to open when the car reaches the gate position.

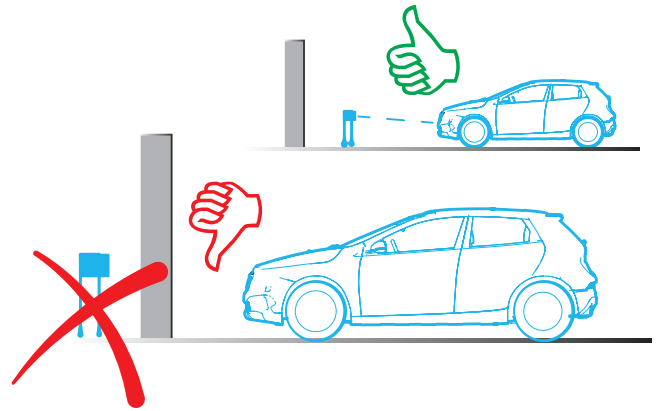

In designing the access point, avoid the possibility of obstructions of the line of vision between the number plate reading position and the camera (for example plants sprouting leaves in spring, or in any case growing in front of the camera).

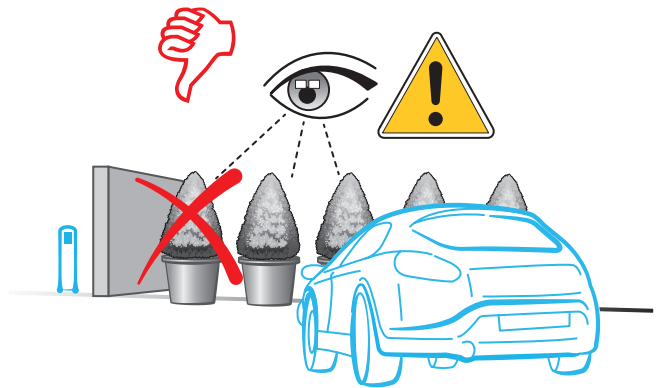

the number plate focus is preset to be read at a distance between 1.5 and 6 metres.

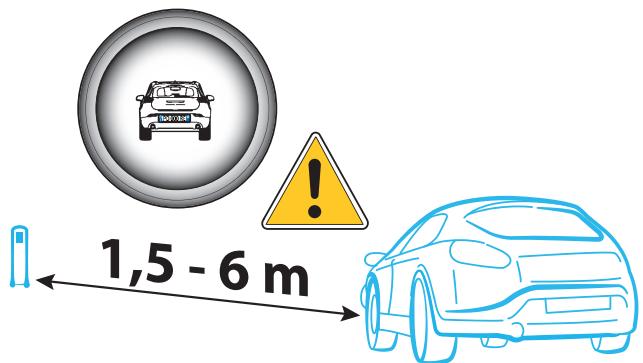

# USING THE CAMERA

## FIRST START-UP

In order to access the **HTTP** screen of the camera, make sure that the computer used is in the same **IP** class of the camera (**default 192.168.0.1** without access credentials). Any updated standard browser may be used. Before connecting and switching on the camera, make sure that the **iZero 2** default **IP** is not conflicting with other network devices (router, server, NAS, etc.) with the same **IP** address.

If your **IP** class is not compatible with the **iZero 2** default class, you can reach the camera with the **SeleaTools** software, available for download at the following link: [https://dl.selea.com/download/9ekk/file/SeleaTool\\_1.6.0.2.exe](https://dl.selea.com/download/9ekk/file/SeleaTool_1.6.0.2.exe). The camera will be searched by **MAC address**, and by highlighting it in the software it will be possible to assign to it a free **IP** from your network. When the firmware is restarted, it will be possible to access the camera using the Internet browser and continue the product customisation procedure.

Click "**Set new parameters**" to assign the new **IP** address to **iZero 2**, which at the end of the restart procedure will be shown in **SeleaTool** with a green border.

**SeleaTool** can also be used to scan the network for free **IP** addresses, to know the **IP** address of your computer, to update the firmware of **Selea** products, and much more. The user manual with full instructions for use is also available online.

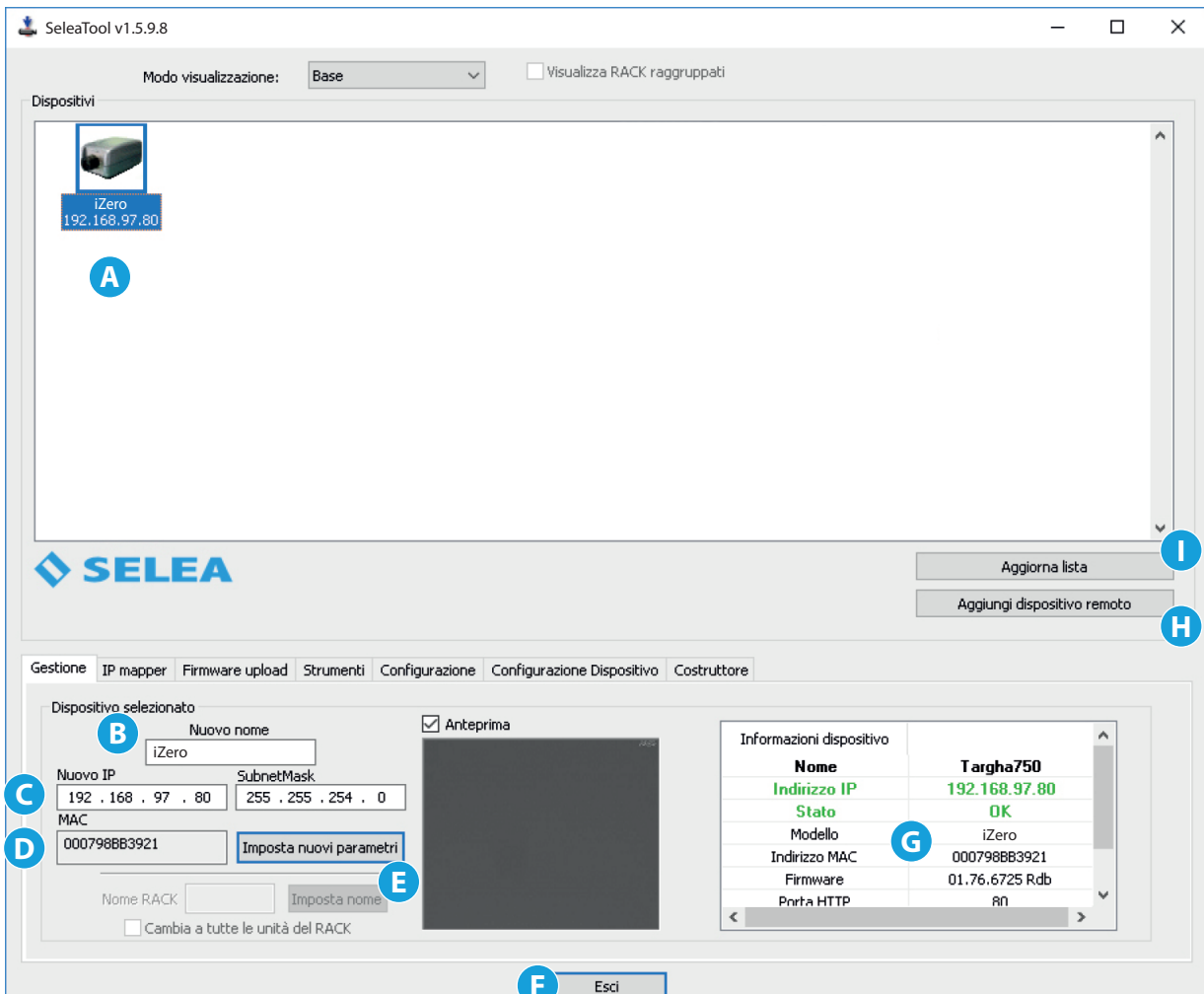

- A** Window showing all the cameras of the network in which the software is installed.
- B** Window showing the model of the camera selected for **IP** address assigning purposes.
- C** Field used to assign the new **IP** address.
- D** Shows the own **MAC** address of the selected camera.
- E** Key used to confirm and therefore edit the new **IP** address that will be assigned to the camera.
- F** Key used to exit the software.
- G** General information regarding the selected camera.
- H** Key used to manually add a camera by entering its **IP** address and other network data.
- I** Key used to update the list of network cameras after the addition of a new device.

## ACCESSING THE CAMERA FROM THE WEB

By entering the **IP** address you assigned to the camera in your preferred browser, you will be able to access the camera login screen.

Using drop-down menu **"A"** in this page, it is possible to select the language in which all camera management software menus will be displayed.

You will then be asked to complete the authentication process by entering your login credentials, whether you are an administrator or a user, by filling the **Username "B"** and **Password "C"** fields.



Once **Username** and **Password** have been entered, click **Login "D"** to access the camera functions.

After completing the login, you will reach the **iZero 2** homepage (**Live page**), and you will be immediately able to see what the camera is framing. Google Chrome offers the best stability results.

Although not necessary, we also recommend the installation of a video playback software to improve image quality: currently available browsers (Edge, Chrome, Firefox, Safari, etc.) only natively support **"M-JPEG Stream"** and **"JPEG Snapshot"**. Although these will allow to see what **iZero 2** is capturing, they produce significant network traffic. Moreover, **"JPEG Snapshot"** playback may not be **smooth**.

The new **iZero 2** host has been fully redesigned to make the product more intuitive. Menus are sorted by topics based on the functions and the parameters most used during configuration.

However, in order to make the most of the product, we recommend that you fully read this manual, which provides a clear and practical explanation of how thanks to the flexibility of its host, **iZero 2** can be suited to several installation solutions.



## LIVE MENU

This screen is the home page that is shown on the browser immediately after logging in.

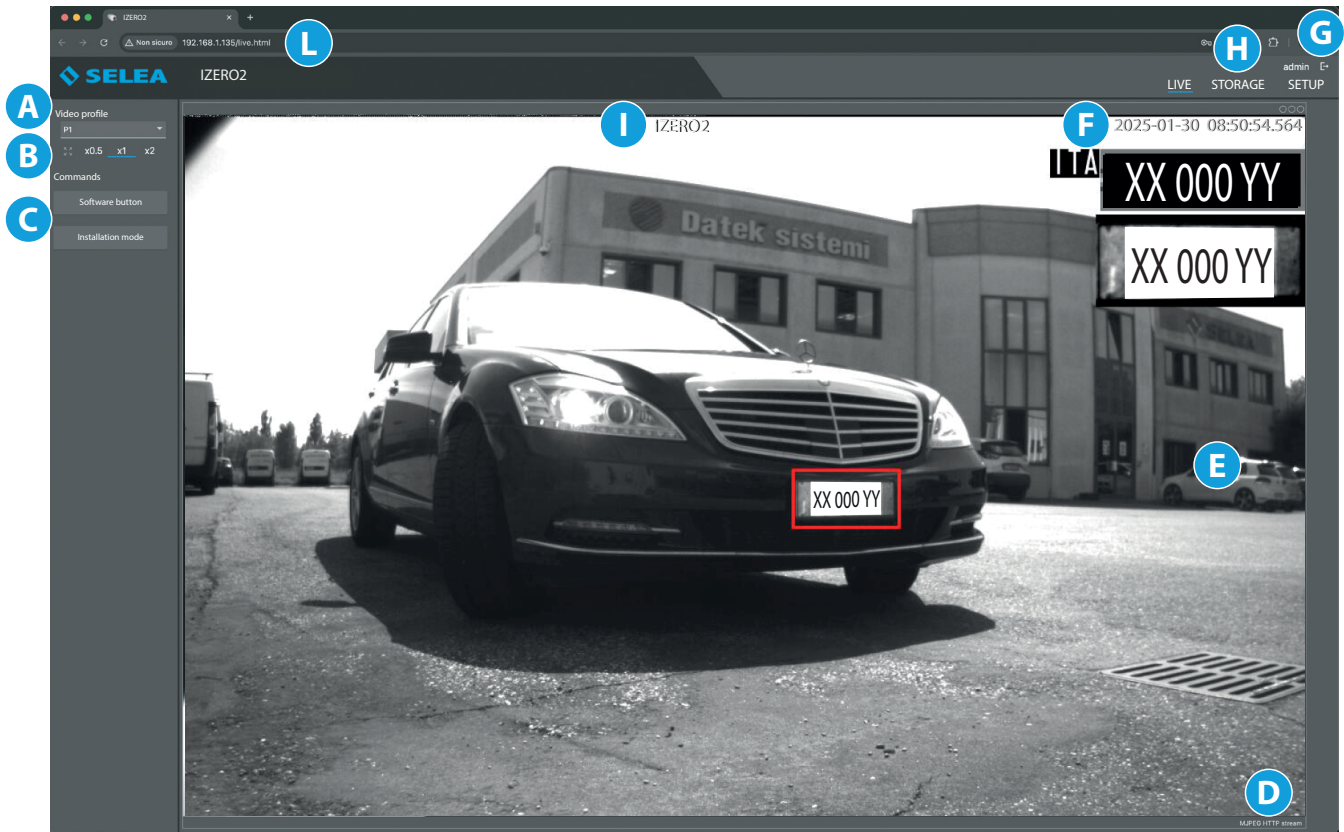

- A** This button will display a drop-down menu for the selection of the video profile; 2 alternatives are available, based on the camera being used, **Number plate sensor (profile 1) - Number plate sensor (profile 2)**. The selected alternative will be shown in the **live-view** screen.
- B** The three buttons are used to set the size of the **live-view** area.
- C** Quick selection buttons:
  - the **"software button"** provides access to the **SETUP** menu in **ACTIONS**, in order to perform some quick configurations.
  - the **"installation button"** activates the software assistant in **iZero 2**, to help you with positioning adjustment and focusing the optical assembly. To leave this function, reload the camera **IP** screen.
- D** It indicates the video **codec** being used by the computer to decompress the video stream.
- E** **Live-view** screen.
- F** Current date and time.
- G** Button used to log out of the camera. You will again be asked to log in using your credentials. The button will always be visible in the three main menu screens.
- H** The three buttons are the main menu controls always visible in all the software screens.

**LIVE menu:** This is the default screen that appears when the **IP** address of **iZero 2** is entered. The real-time images captured by the camera are also displayed here.

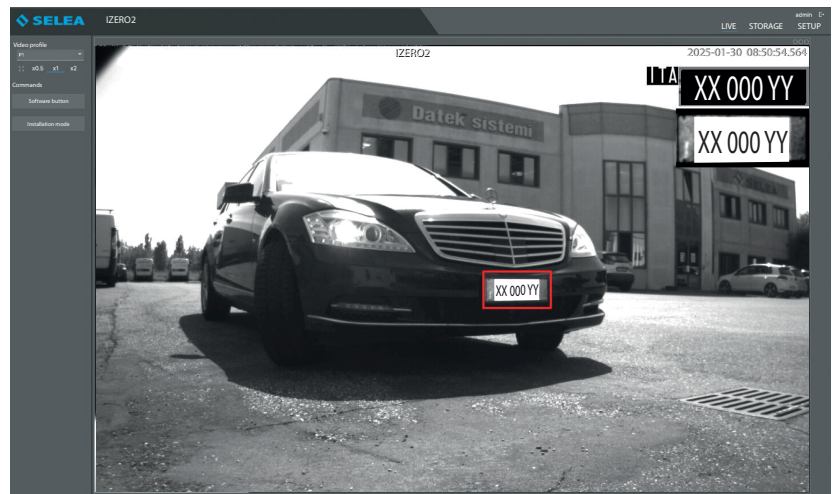

**MEMORY menu:** it can be used to access information stored in the **MicroSD** memory inside **iZero 2**: specifically, it makes it possible to display and upload/download snapshots and lists. It is possible to upload to the memory TXT files containing number plate lists (Windows notepad can be used as editor). In this case, it is important to make sure that each number plate has its own row and that no comments or other text are included.

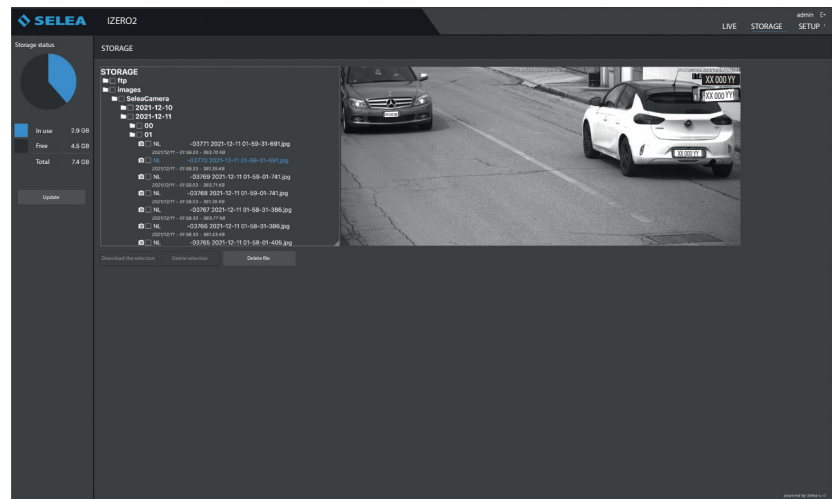

**SETUP menu:** it can be used to customise many aspects of **iZero 2** so that it meets your needs as much as possible. As this product has an extremely high number of functions, the amount of items in the setup section is obviously very high, although not all of them will be required. In order to help you to remember their positions inside the setup section, the parameters have been sorted into pages and sub-pages: on the left of the screen are a number of pages, named based on the context in which the parameter is used. When a page is clicked, a drop-down window opens listing the sub-pages relevant for the topic of the page.

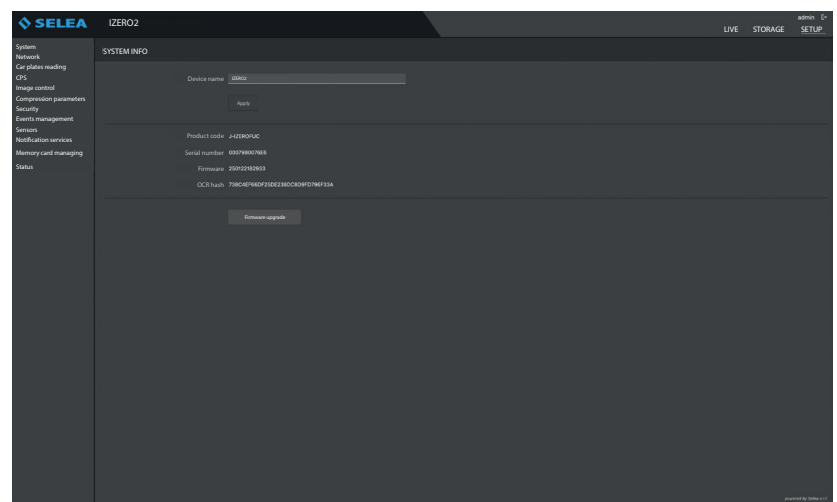

- I** This is the name assigned to the camera.
- L** **IP** address entered in the browser to connect to the camera.

## MEMORY MENU

As previously indicated, it can be used to access information stored in the **MicroSD** memory inside **iZero 2**: specifically, it makes it possible to display and upload/download snapshots and lists.

All the data are sorted into folders: the main folder is called **STORAGE**. Sub-folders will be named based on the capture **DATE**. Further level sub-folders will also be created based on the capture **TIME**. Lastly, there is also a **JPG** file, consisting of the captured number plate number, the sequential capture number, the exact capture time and date.

Select one of the **JPG** files in the list to display the image of the vehicle captured, with the number plate highlighted.

The screenshot shows the SELEA IZER02 STORAGE interface. On the left, there is a 'Storage status' section with a pie chart (B) showing 'In use' (2.9 GB) and 'Free' (4.5 GB) space, with a total of 7.4 GB. Below this is an 'Upgrade' button (A). The main 'STORAGE' section displays a file tree (E) with folders for 'ftp', 'images', 'SeleaCamera', and sub-folders for dates '2021-12-10' and '2021-12-11'. Under '2021-12-11', there are sub-folders '00', '01', and '04', each containing several image files (e.g., 'NL -03771 2021-12-11 01-59-31-691.jpg'). A large image (F) shows a white car with a license plate 'XX 000 YY' highlighted. At the bottom, there are buttons for 'Download the selection' (C), 'Delete selection' (D), and 'Delete file' (G). The top right corner has 'admin' and 'LIVE STORAGE SETUP' links.

- A** Button used to update the list of the recordings made.
- B** It indicates the capacity and the free space of the memory card where the data is saved.
- C** Button used to download one or more selected data to the pc. The file will be saved in the selected browser file download folder and will take on the name of the camera, with the **".gz"** extension.
- D** Button used to delete one or more selected files from the memory.
- E** List of the folders of the readings performed and saved by the camera.
- F** Image showing the vehicle captured by the camera, with the number plate highlighted.
- G** Button used to delete the individual selected file.

In order to download a whole folder relating to a group of captures, **"flag"** the folder and press **"Download the selection"**.

This screenshot shows the SELEA STORAGE interface with a folder selected. The file list (E) shows the folder '2021-12-10' selected. On the right, the 'Folder name' is '2021-12-10' and the 'Full path' is 'STORAGE/images/SeleaCamera/2021-12-10'. Below the file list, there are buttons for 'Download the selection', 'Delete selection', and 'Delete file'. The file list includes files like 'cb 81.bmp', 'cb 80.bmp', 'cb 114.bmp', 'cb 111.bmp', and 'NL\_XA404ND 99 04760 2024-09-26 14-17-24-430.bmp'.

## SETUP MENU

As previously discussed, this menu gives the possibility of customising **iZero 2**. This menu includes many functions and sub-functions, which may be available or not based on the needs of the user.

Below is an explanation of all the menu items, and the various functions.

We remind that all changes must be confirmed using the **"Save parameters"** button in the screens.

### SYSTEM

Using this screen, it is possible to adjust the main system functions managed in the camera: these are split into four sub-menus: **Information - Clock - GPS coordinates - Licence management**.

#### Information

It groups together all the product information, which can be useful in case of need of technical support from **Selea**.

- A** It is possible to change the name of the device, which will be displayed in the LIVE menu and used for notifications requiring the device name.
- B** Own camera data.
- C** Button used to update the camera firmware.

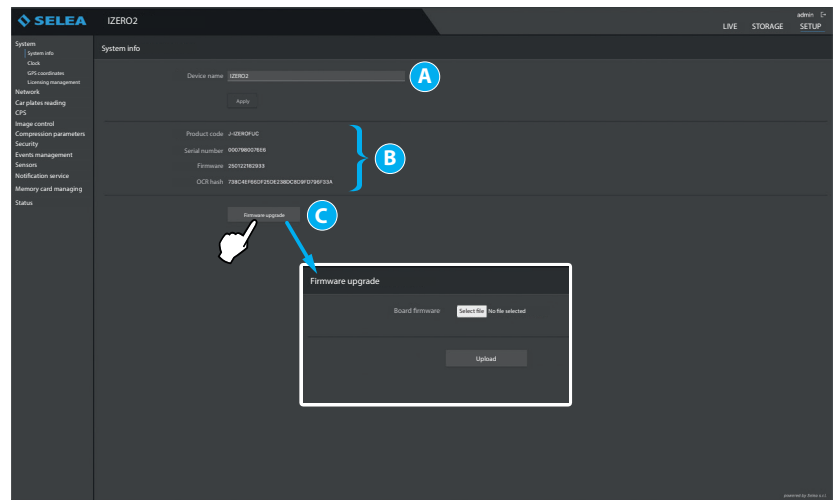

#### Clock

This is used to update the date and time of the device. It is important that these details are correct, as the metadata of the snapshots will include the date and time of the device! If they are wrong, the archiving software may store the snapshots incorrectly, making them difficult to retrieve, especially if planned automatic cancellations are active. In case of black-out, a battery keeps the date system active for at least one week.

Upon restart, date and time will automatically be restored.

- A** Date and time displayed in the **LIVE** menu.
- B** Date and time adjustment field. It can be the same as that of the computer where the camera is displayed, manually set, or synchronised with an external NPT server by entering the **IP** address.
- C** Time zone adjustment field.

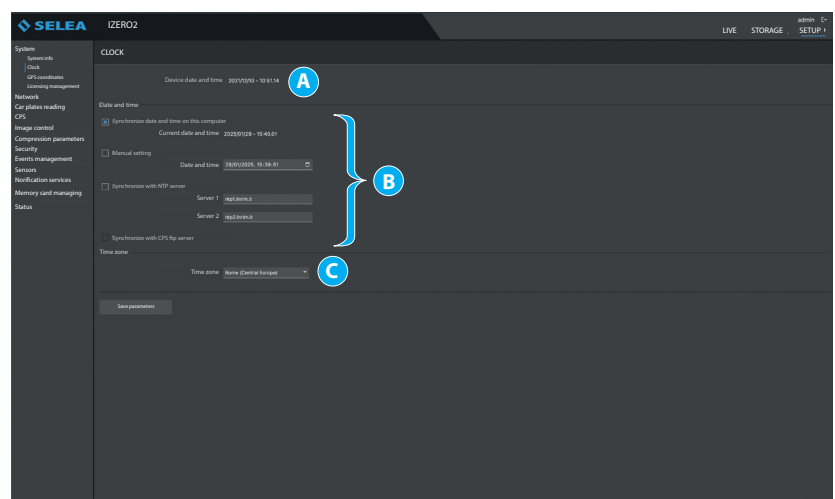

### GPS coordinates

To assign the geographical coordinates for the installation: the snapshots will include the geographical details of the captured position. In the **“latitude”** and **“longitude”** fields enter the values of the GPS coordinates in decimal format (e.g. 44.9403428 and 10.4814643).

In addition, it is possible to assign **directional labels** that allow to tell the movement direction of the detected vehicle based on the number plate read, front or rear.

For example, in the **“REAR”** and **“FRONT”** fields it is possible to enter the cardinal points or specific directions, to indicate where the vehicle is heading.

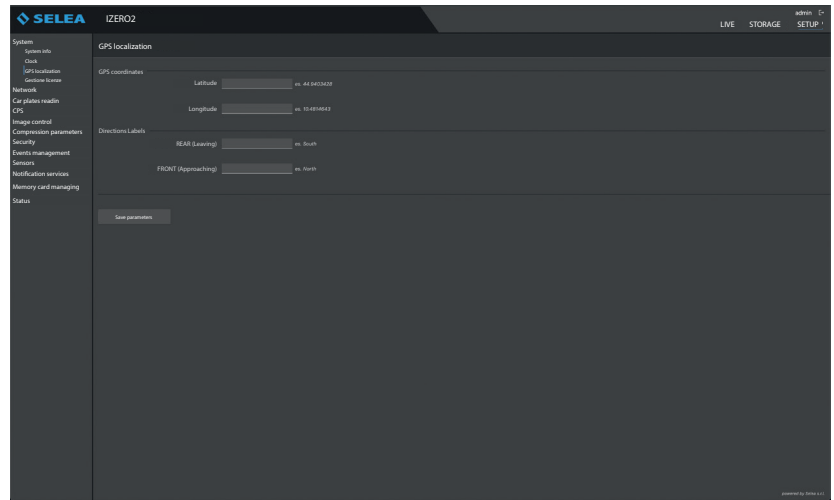

### Licence Management

It Allows the activation, by means of an activation code, of licences relating to:

- A Integration with Hub Parking systems:** this is a plugin that allows the integration of the camera into Hub Parking systems.

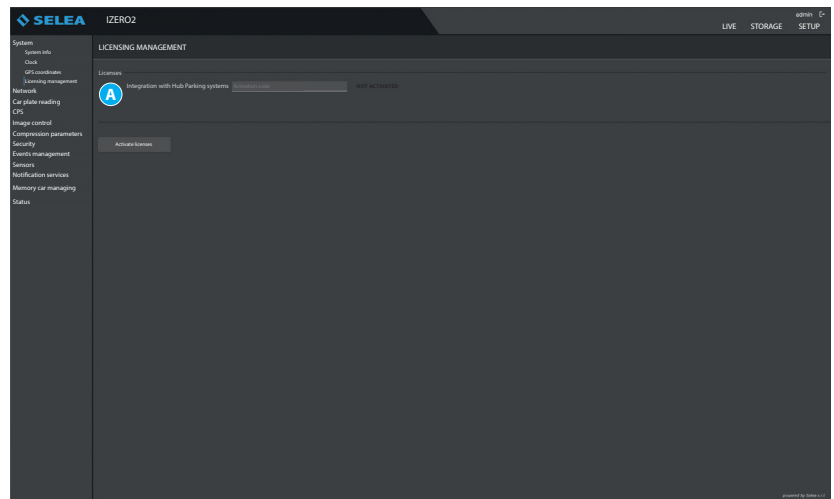



## NETWORK

### General

It can be used to change/set the camera network configuration.

**A** Assigning parameters for the configuration of the camera within the network; Selea discourages from using the DHCP method if the product must interact with CPS or other software whose addressing is indeed based on the assigned IP.

**B** If enabled, it will project on your network information regarding its configuration and potentials, also making it visible to ONVIF standardisation compatible software programs (Open Network Video Interface Forum).

**C** Enabling the SNMP agent allows the manager of network servers and devices to monitor network utilisation and keep track of important issues, such as uptime and other device parameters.

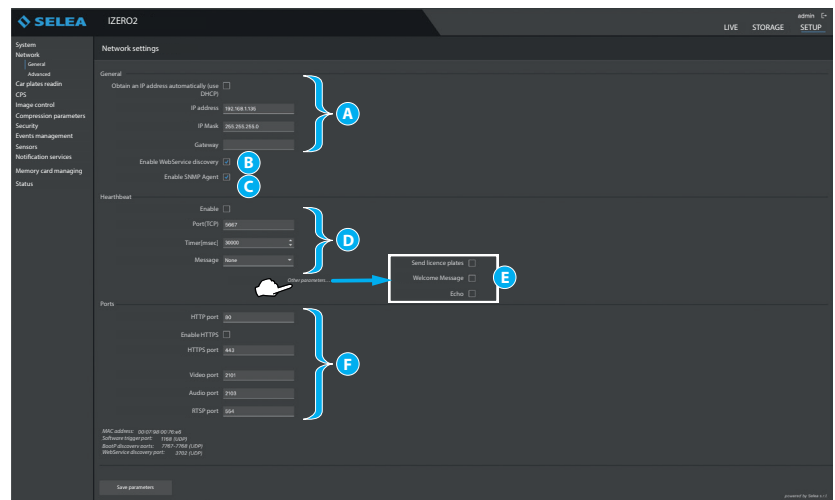

**D** Enabling Heartbeat allows to monitor the correct operation of the camera, which will send standard or customised messages to your client (e.g. Telnet) with customisable frequency on the specified TCP port.

**E** Other configuration parameters for Heartbeat enabled are:

Send number plates: it allows to notify each number plate read to your client.

Welcome message: it allows the forwarding of a network message upon first connection between camera and client.

Echo: it allows real-time notification of every character typed on the keyboard.

**F** On the other hand, port customisation will only be necessary in the specific cases when Targa must interact with not particularly flexible third-party software, or when such requests are already used by other systems. These values are assigned by default and can be modified.

We remind that the same ports must be configured on the router to which the camera is connected.

### Advanced - DNS

If the camera must use the Internet (for example for geolocalisation purposes), make sure to enter any **DNS** server parameters.

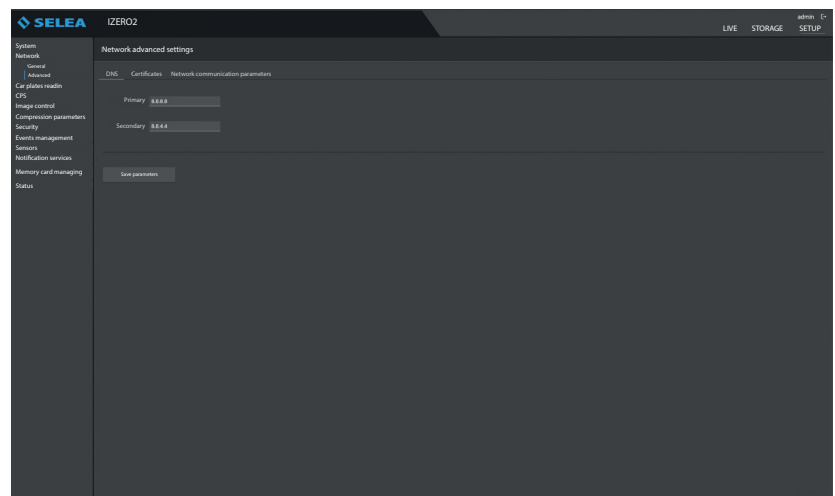

## Advanced - Certificates

From here it is possible to insert an SSL certificate to guarantee an encrypted and protected connection between camera and client.

- A** Certificate Data
- B** Allows you to automatically generate a self-signed certificate guaranteeing a secure connection to the camera.
- C** Allows you to download the installed certificate which can be used to configure a client to accept the connection only from this server.
- D** Allows you to upload a certificate authenticated by a certification authority.

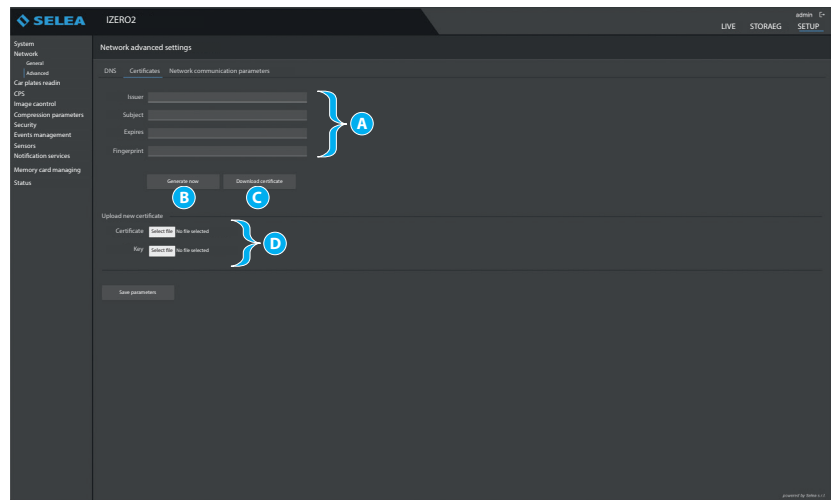

## Advanced-Network Communication Parameters

It can be used to change the size of the packets to sizes smaller than the standard one for Ethernet networks, sometimes used in VPN or mobile connections. This modification makes it possible to avoid packet fragmentation and the introduction of unwanted latency in the reception of the same.

Before changing this parameter, it would be appropriate to measure the transmission line MTU, or the smallest MTU of any of the connections making up the "transmission route" from the Targa address to the destination address. In other words, the transmission MTU is the largest MTU value that may travel through the path without further fragmentation.

It is also possible to set the connection speed between three values:

- Auto
- 1Gb/s
- 100Mb/s

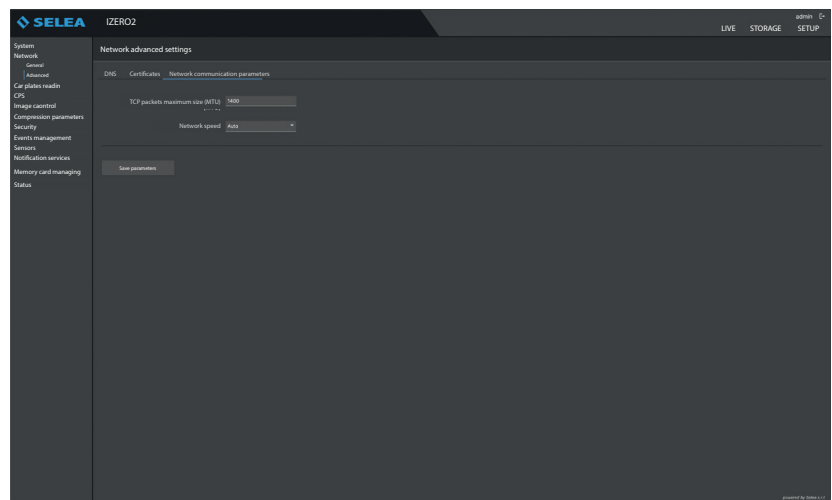

## NUMBER PLATE READING

### General

Here you can adapt the operation of the **OCR** on board of the camera to your specific needs, taking however into account that the default settings are those that Selea considers the most appropriate in most situations.

- A** With the “flag” ticked, number plate reading is enabled. Otherwise the camera will work in video surveillance mode. It is recommended that reading is disabled in case of system debugging.
- B** It allows to select the algorithm
- C** Percentage confidence value for the recognition of the character analysed by the system **OCR**. In case of no recognition, the “~” character is assigned. A maximum of two characters per number plate may not be recognised.
- D** This sets the minimum number of characters of the captured reading for it to be considered a number plate. We remind that the new Italian number plates have 7 digits (AA 123 BB).
- E** This parameter is useful, for example, to discard number plates marginally framed in relation to the main search area (for example to filter opposite lane front number plates, smaller in case of road check points).
- F** If enabled, it excludes the reading of number plates on two rows (for example motorcycles or old off-road vehicle number plates). It decreases the reading field, particularly when reading is only required for the front number plate.
- G** It gives the possibility of avoiding the reading and forwarding of incomplete number plates that still exceed the minimum set length, particularly when vehicles are travelling at slow speed, such as when crossing accesses. Before sending the number plate, the camera waits for the last consecutive character to move away from the edge of the framed area by a distance sufficient to assume that there will not be further characters that may be considered part of the number plate during the analysis. However, this function also entails that even if complete, the number plate will only be captured once it moves away from the image edge, as **iZero 2** waits for the possibility of further characters.
- H** If enabled, it allows a notification to be sent when the system is unable to read a number plate.
- I** It identifies in a way other than “**UNREAD**” badly read number plates from advertising signs, or other captured items:
  - Standard:** the snapshot is classed as “**UNREAD**”.
  - Advanced:** the snapshot is classed as “**unread\_fake**” as the text detected cannot be part of number plate.
  - Disabled:** the reading is not discarded from the processing and anything recognised as text will be classed as a possible number plate.

- L** If enabled, in case of contemporary transit of two vehicles (e.g. dual lane captures, rear number plate + front number plate of the vehicle on the other lane or lorry number plate + trailer number plate, or vehicle + kemler number plate) several separate notifications will be sent (active by default).
- M** If enabled, it allows the reading of the old or foreign number plates with black background and white characters.
- N** If enabled, a metadata is added to the snapshot, allowing the software to sort the snapshot based on the transiting direction of the vehicle.
- O** If enabled, it allows the reading of Russian number plates.
- P** If enabled, it allows the reading of number plates with Arabic characters.
- Q** If enabled, it turns the letters "ö", "ü" into "O", "U".
- R** Used to also forward the captured number plate to the camera serial port, if required also coded in one of the formats indicated in the drop-down menu.
- S** Used to also forward the captured number plate to the Wiegand interface, if required also coded in one of the formats indicated in the drop-down menu.
- T** Modification of the **OCR** behaviour in relation to time:
  - Continuous reading:** OCR always active and continuous search of possible number plates within the frame. How long the same number plate can remain in the frame before the camera records it as new must be indicated in the "**time window**" field below.
  - Weighted:** in this case multiple readings of the same number plate are carried out, and recognition is validated (and possibly an event is generated) only if at least 50% of the readings are consistent. Function recommended in situations when vehicles move slowly or stand still for a few seconds in front of **iZero 2**, allowing the capture of a sufficient number of samples. The number of subsequent readings is specified in the field below.
  - External trigger:** the **OCR** is only interrogated when the vehicle produces an input on the camera inputs (due to loops or other devices), even some milliseconds before (thanks to the capture pre-trig field). The "**time window**" field makes it possible to set for how long the same number plate can remain within the capture area before being considered new. It is in fact not necessary for the activation loops to be exactly at the capture position: they could indeed be positioned before. If no number plate is detected for the triggered event, the image is nevertheless sent with the label "**TRIGGER**".
  - Redundant reading:** it helps to further improve reading reliability. The number plate is only logged after reading a second consecutive frame after the first one, applying statistical criteria in order to ascertain which reading is more reliable. This function is not considered active if the "**Enable travel direction evaluation**" flag is also active.
- U** it gives the possibility of applying further software filters to the reading, for an even more reliable result.
  - No control:** the number plate is read character by character, with the final result only containing the characters that have exceeded the confidence threshold set in the appropriate field (default 60%).
  - Syntax check:** the reading algorithm will attempt to obtain a result consistent with the number plate syntax. In this way, there will be the a higher probability of obtaining complete readings of the characters of a number plate, and overlook any external characters.
  - Wrong character tolerance:** as above, but allowing for syntax errors (the maximum number of errors, up to two, is specified in the field below, with the character not exceeding the confidence level set replaced by "~"). In this way, the number plate is still classed as "**read**" (although with errors).

## Display

It groups those number plate reading parameters dealing with how the number plates will be presented to the observer.

- A** This function facilitates the calibration of the optical assembly by inserting near the read number plate the height in pixels of the character and the focusing at the furthest point of the capture. To ensure optimal reading, the minimum character height must be at least 20 pixels. It will also be possible to ascertain that the focusing of the number plate is as good as possible. For this, it will be necessary to adjust the ring nut of the optical assembly to the highest possible focus value. To facilitate the procedure, during the rotation the highest captured value will be displayed in brackets for a few instants.
- B** It rotates the video capture by 180° in order to meet some installation needs, such as ceiling assembly.

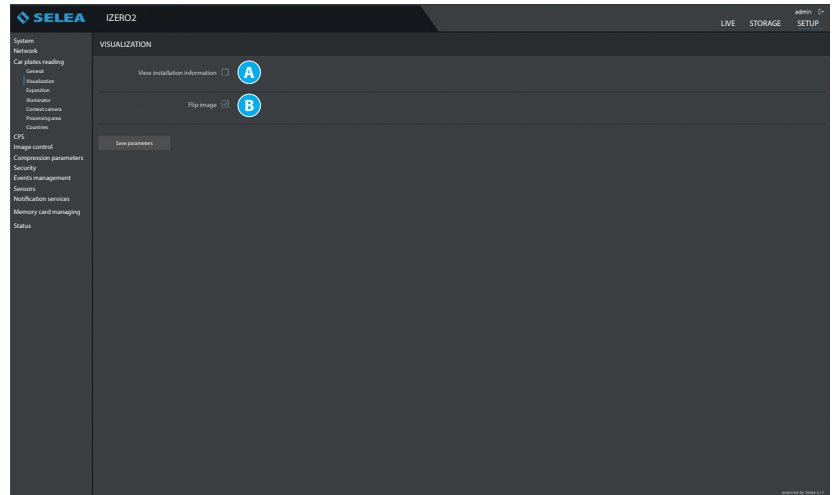

## Exposure

It can be used to adjust the parameters of the built-in high-speed sensor. It includes two automatic gain and exposure time adjustment modes, in order to help obtain an appropriate capture of the number plate in any external lighting conditions. The default parameters are optimised at the factory, and as a rule should not be changed unless recommended by **Selea** technical support service.

- A** **Triple exposure:** mode expressly devised by Selea to ensure the reading of number plates in any lighting conditions, including extreme (backlighting, sun reflecting on the number plate, etc...). It has a slight negative effect on the speed of the Live stream displayed. It adjusts the parameters of the sensor for the optimisation of the visibility of the number plate, overlooking the rest of the frame. To ensure optimum capture, reading trials are carried out with 3 different positions.
- B** **Double exposure:** mode devised by Selea to ensure the reading of number plates in any lighting conditions, including extreme conditions (backlighting, sun reflecting on the number plate, etc...) for the new number plate reading algorithm. It adjusts the parameters of the sensor for the optimisation of the visibility of the number plate, overlooking the rest of the frame. To ensure optimum capture, reading trials are carried out with 2 different positions.
- C** **Automatic exposure:** useful during the installation in order to assess framing. However, it does not guarantee optimum number plate reading in all conditions. Using the target field, it is possible to adjust brightness in the absence of number plates.
- D** **Fixed exposure:** the exposure remains unchanged and set on the user's values.

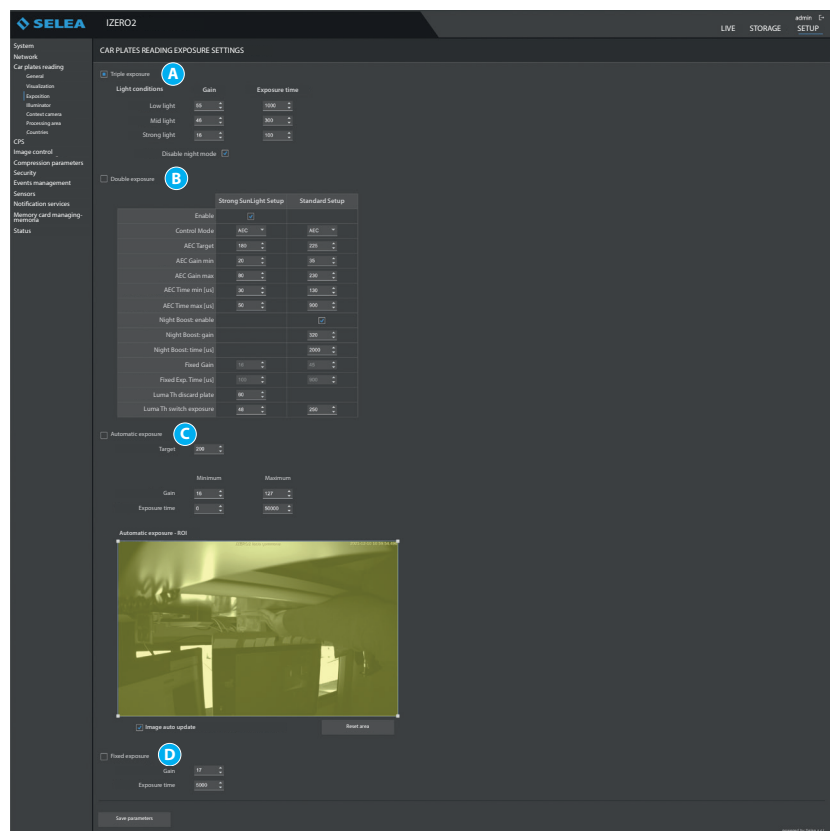

### Illuminator

It is important to remember that the **iZero 2** built-in high-speed optical sensor is an infrared sensor with visible light filtering optics. Therefore, in order to obtain visible images, the framed area must be sufficiently illuminated by infrared rays. From the above, it is easy to understand that in order to ensure the correct operation of **iZero 2** the built-in light should never be switched off unless internal tests are being completed, or in case of out-of-range installation requiring additional **IR** light.

- A** Enable the function
- B** Modifiable values

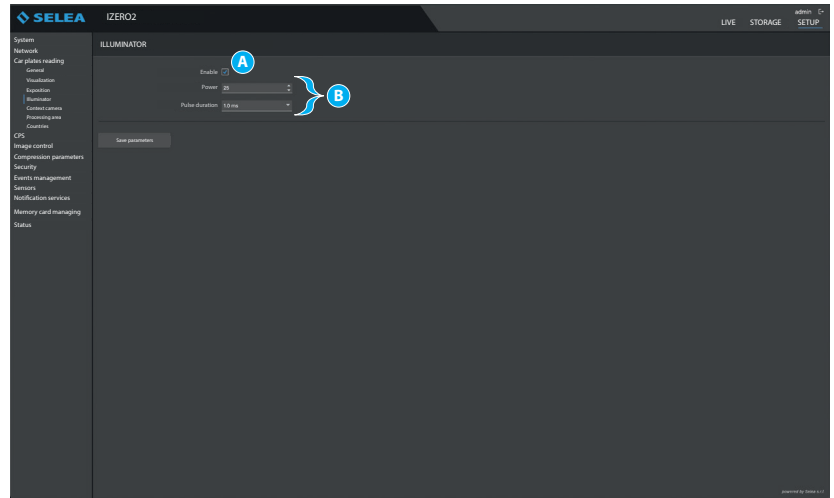

### Context camera

it gives the possibility of configuring the acquisition of snapshots from additional cameras.

If your ANPR has a “double eye” function (integrated colour context camera), there could be two attached contextual images, indicating here the presence of a camera that captures the scene from a different point of view.

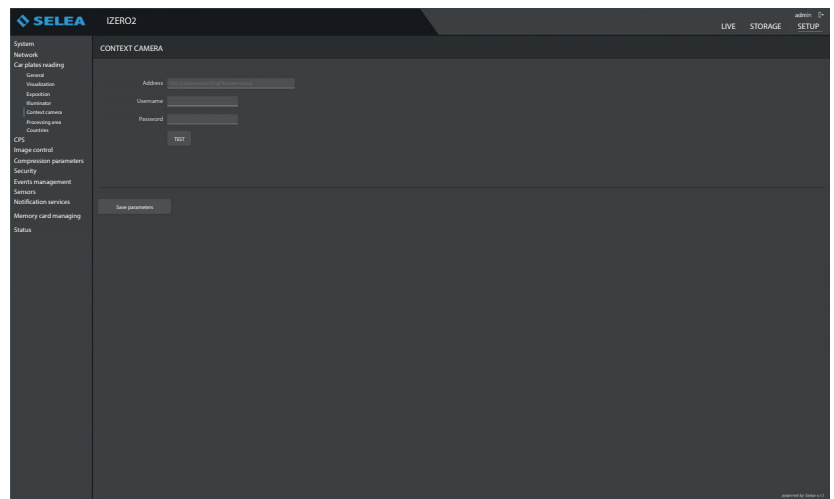

### Standard CPS use

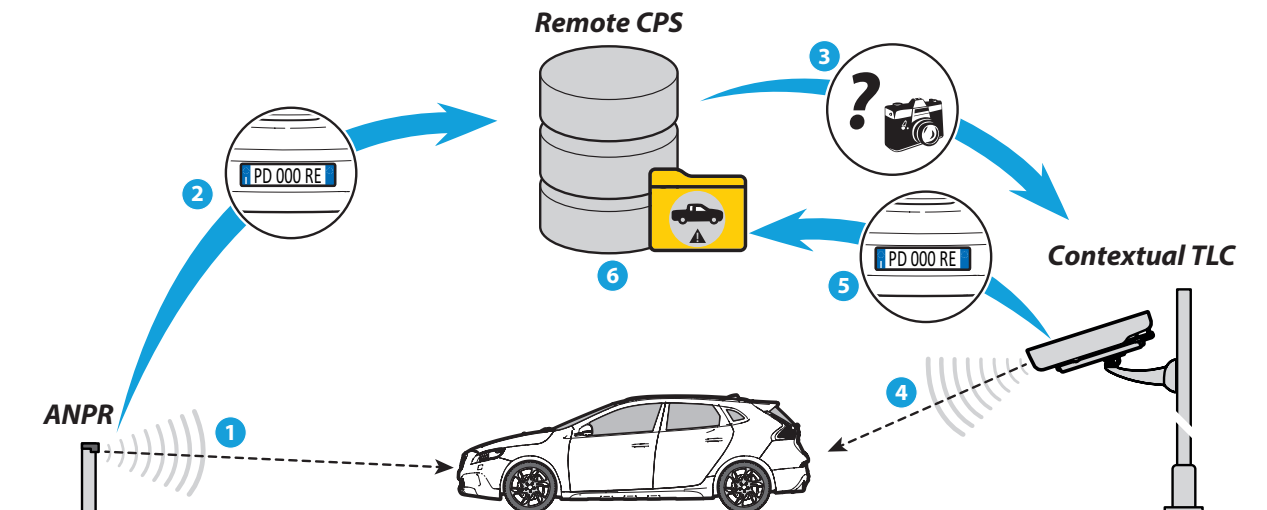

## iZero 2 CPS use

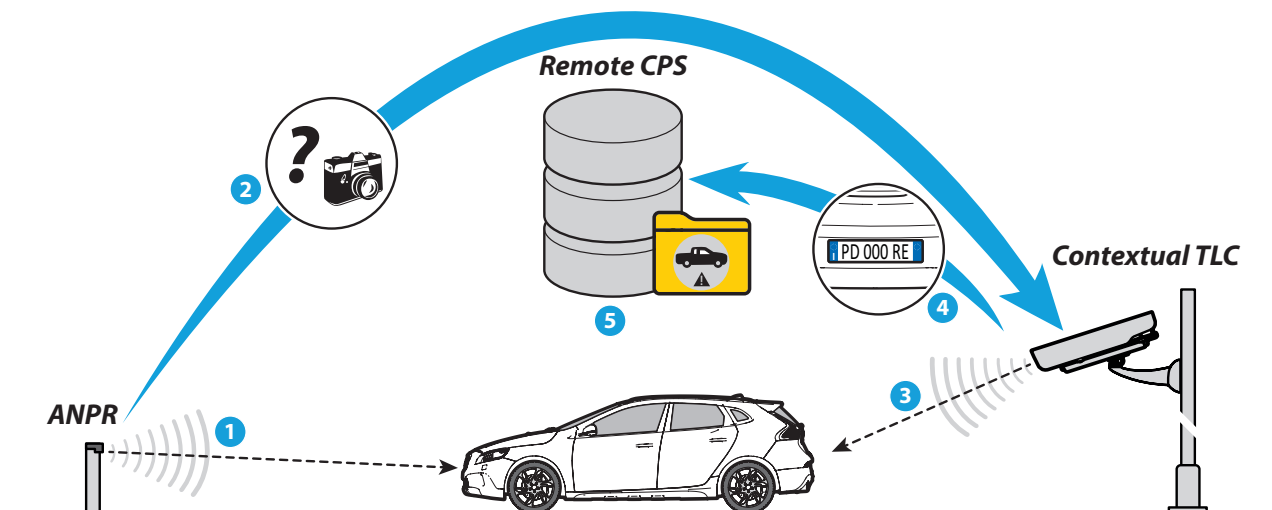

As shown in the drawings, with **iZero 2** interactions between the capture position and the remote **CPS** server are greatly reduced to the advantage of the contextual frame capture speed and the reduction of band consumptions.

### Processing area

It gives the possibility of isolating those parts of the video recording that could interfere with the correct identification of the number plates.

Some examples: screening the lane opposite the capture lane, to avoid the reading of unwanted number plates, removing rest areas from the field of view, preventing the algorithm from continuously searching for number plates from advertising signs or regular patterns such as fences or pavements, etc...

Move the mouse pointer on the green squares at the corners of the display area and drag them to the desired point.

The area outside the polygon will not be considered in the **OCR** video analysis.

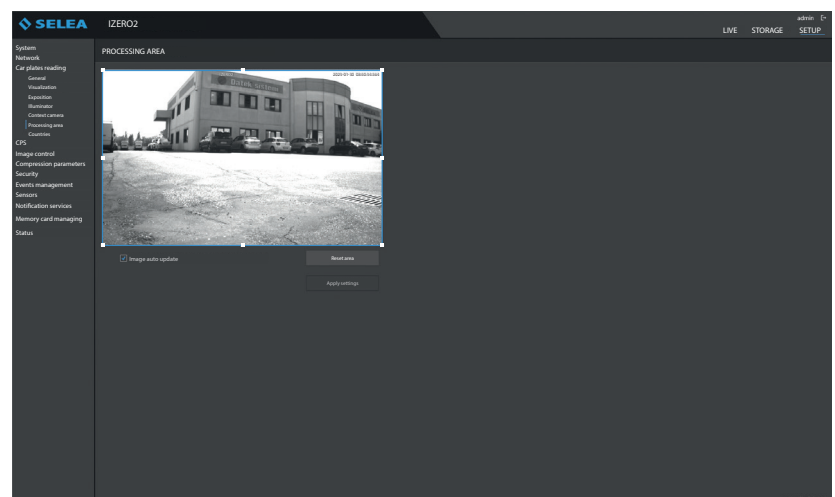

## Country

It allows to indicate the number plates of which countries must be recognised by the camera. The list includes all the countries of the EU area and some countries outside the EU (Florida), as well as some special types, such as ADR tables and container ILU-BIC codes. It is possible to select any number of countries as the same time without any impact on the overall performance of the camera. It is however recommended that recognition of number plates from countries that are unlikely to transit through the area is not enabled. This is to avoid that a number plate with similar syntax is classed by mistake as belonging to an enabled unlikely country.

**A** Enable/disable the function.

**B** **Italian number plate syntax check:** it checks that the read number plate complies with the syntax rules of Italian number plates, applying any required corrections. If after the corrections the number plate still does not comply with such rules, it is discarded and labelled as "UNREAD".

**C** The country of installation of the camera must be indicated here.

**D** List of countries.

**E** This function is enabled by default and enables the recognition of the nationality of number plates by means of a neural network.

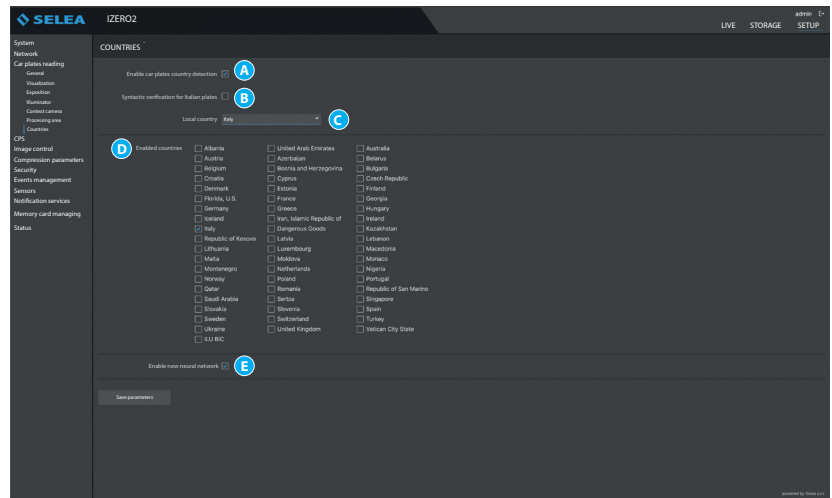

## CPS

One of the most important new features of **iZero 2**, giving the possibility of carrying out advanced checks on the number plate immediately after capture.

### Record viewing service

It is possible to enter the address of a **CPS** service connected to remote **databases** (Transport or Home Offices, etc...) in order to complete the captured snapshot with information regarding the status of the read number plate. The added information will obviously depend on the database accessed by the indicated **CPS**.

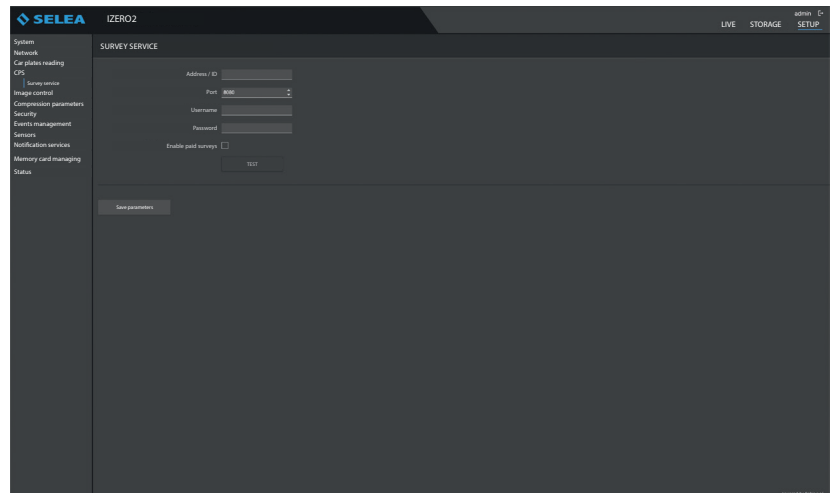



## IMAGE CONTROL

### OSD

All the **iZero 2** models allow the superimposition of current information and camera name. The choice can be made for the number plate sensor.

To enable the information to be displayed, the relevant box must be flagged.

Furthermore, using the drop-down menu, it is possible to select the position where the information must appear with respect to the captured image.

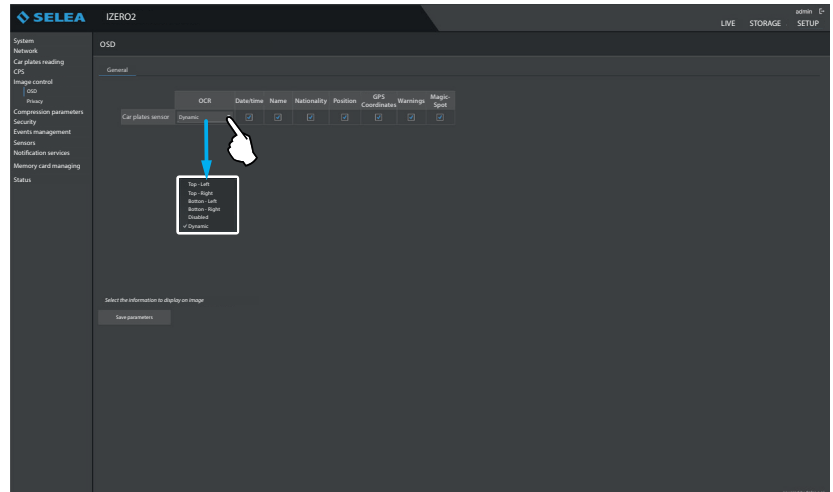

### Privacy

Using this function, it is possible to darken people's faces in the frame so that they do not appear in live-view, in the snapshots and any recordings. Number plates will still be read and stored.

- A** Frame on which to draw the face darkening rectangle.
- B** **"Remove area"** key, to be pressed to remove the previously configured darkened area.
- C** **"Enable settings"** key, to be pressed after setting the darkened area.

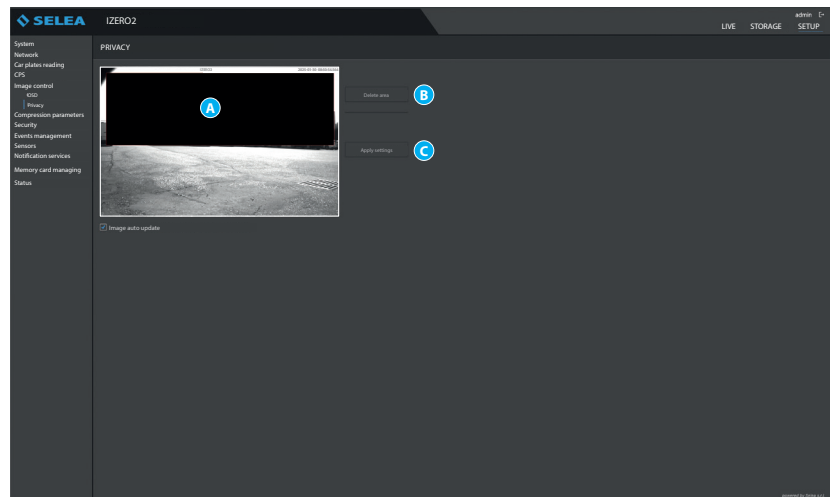

## COMPRESSION PARAMETERS

### Video

**iZero 2** manages 2 different streaming video profiles, which can be independently configured. The first profile refers to the video stream captured by the built-in high speed sensor, the second one still to the number plate sensor but configured differently. The parameters that can be changed are the same for each profile, although their values will depend on the actual profile.

**Resolution:** to select the size of the supplied image.

**Coding:** it allows to select the type of compression applied to the video stream for each profile.

**MPEG4 (default):** the video stream is transmitted with less bandwidth.

**H264:** the video stream is of high quality and, thanks to its compression, is transmitted with a lower bandwidth.

**H265:** the video stream is of higher quality than H264. Moreover, it is also particularly suitable for 4K and HDR videos, as it can handle higher resolutions and better frame rates.

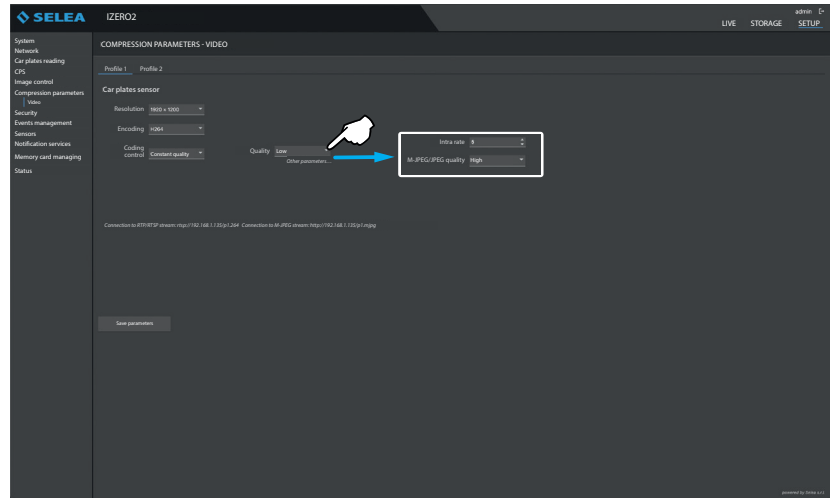

**Quality:** allows you to select the quality of the images displayed with each profile from five levels. Higher quality will entail higher band requirements and higher snapshot kb size. This may cause delays in transferring the images (depending on network and network traffic) and in uploading them to the hard-disks.

**Coding control:** it gives the possibility of specifying which parameters should be kept constant in case of network performance variations.

**Band:** in case of network channel quality decrease, the number of frames sent will automatically be reduced, although they will be of the quality selected by the user. This menu is only present in **Profile 2**.

**Intra rate:** only for MPEG4 coding, it indicates the interval at which intra-frames are included in the video stream. Video streams compressed using the MPEG4 standard consist of two types of frames: intra-frame and p-frame. "Intra" frames contain a complete image, similar to a JPEG, and are also called "key frames". "P" or "predicted" frames do not contain a complete image, but only information regarding the differences between the current frame and the previous key frame. If subsequent frames are very similar to each other, this technique allows to reduce band usage whilst maintaining good image quality. It is however necessary to update the key frame at regular intervals, by including an intra-frame in the stream. The "Intra-Rate" field can be used to indicate every how many frames an intra-frame must be included. The more the distance between intra-frames, the more video stream compression will be possible, at least in almost static captures. However, it must be considered that when playing back a recorded video, the cursor may only be placed near key frames. Therefore, excessive distance between intra-rate frames may not be appropriate. An "Intra-Rate" of 100 is normally a good compromise.

**M-JPEG/ JPEG quality:** changes the quality of the image you see by watching the live image via the browser

## SECURITY

### General

The remote access block for some functions is enabled/disabled.

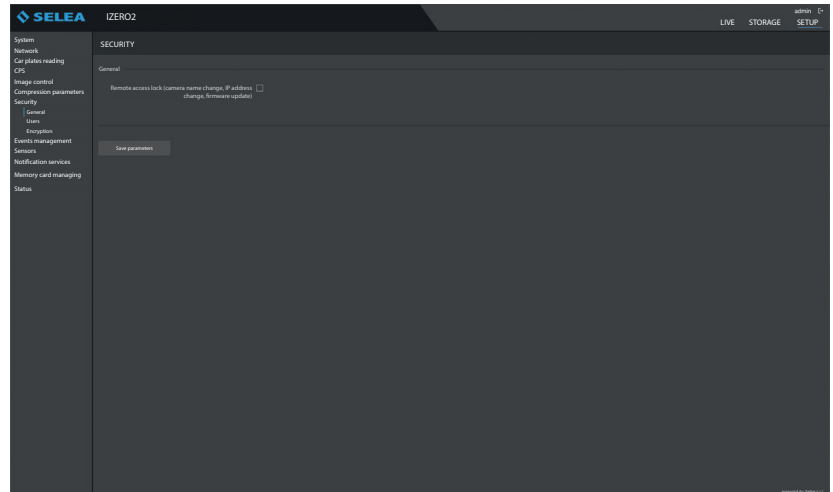

### Users

Camera viewing access credentials may be set with both **Administrator** and simple **User** authority.

Three **user** alternatives are available:

**Disabled:** the user cannot access the camera.

**User:** the user can access and view the camera, but not change parameters.

**Administrator:** the user has the same authority levels as the administrator.

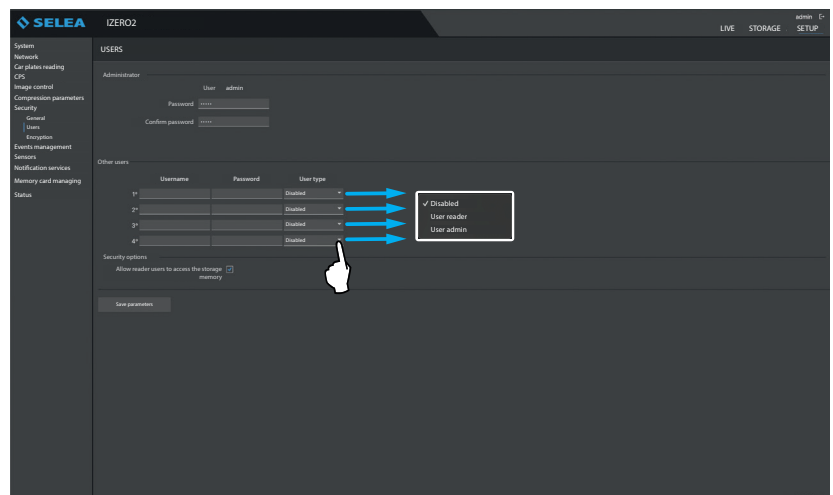

### Encryption

This is a function that allows notifications to be encrypted with their own encryption key.

**A** It enables the encryption function.

**B** Encryption key input field.

**C** Field for re-entering the encryption key.

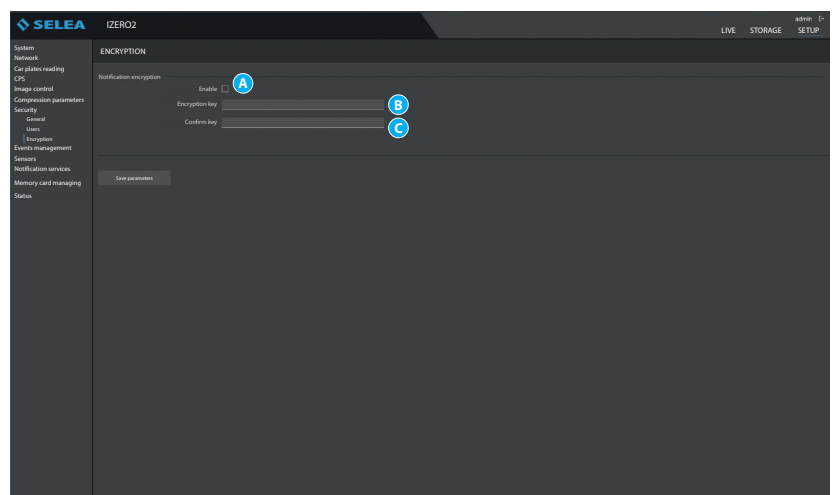

## EVENT MANAGEMENT

“Events” are physical or software situations foreseen or planned by the user, which trigger **iZero 2** to respond with an action that can be physical (activation of an output), software based (e.g. the forwarding of a notification), or both.

Example:

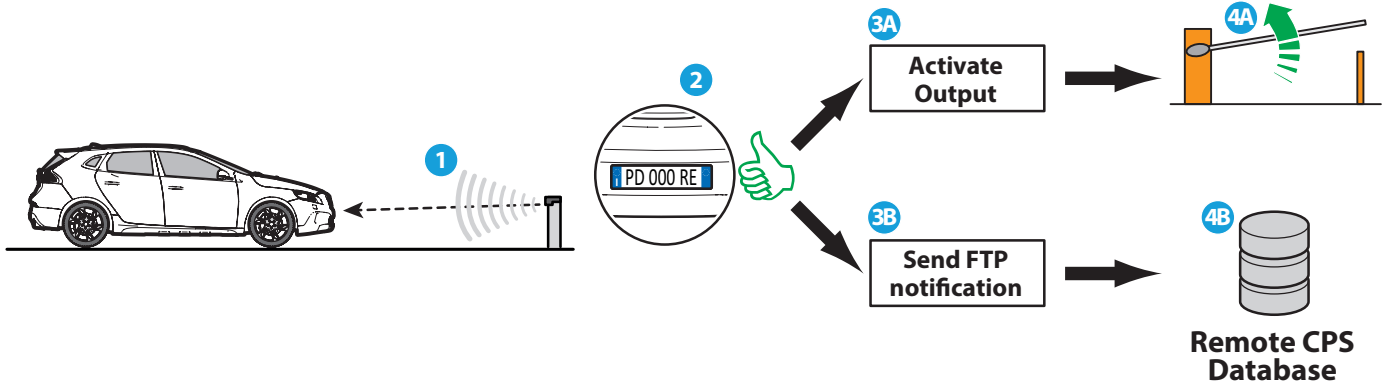

### Number plate control list

This sub-page can be used to create/load inside the camera some number plate lists to associate with certain “actions”, such as notification of passage, or activation of electro-mechanisms.

There are already two lists (**WHITE LIST** and **BLACK LIST**), in addition to the **OUTSIDE LIST**. For each list, it is now possible to individually define a behaviour in relation to 3 types of possible actions; these are:

- **Send notification;**
- **Send email;**
- **Activate output.**

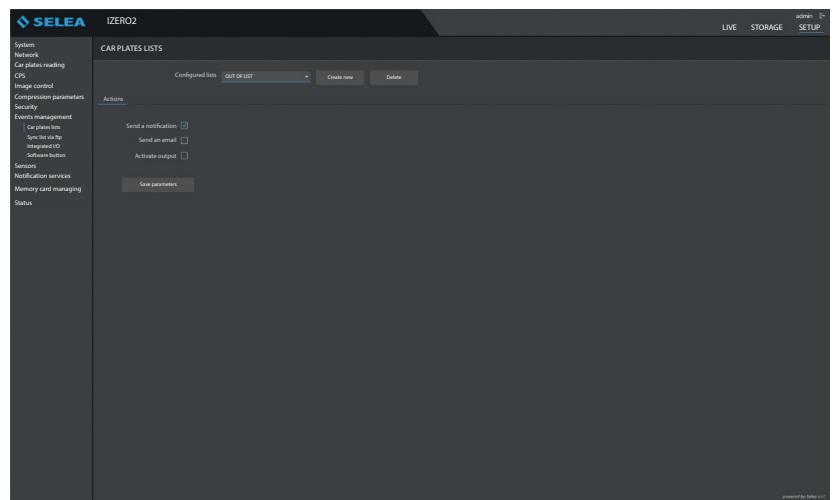

It is now also possible to create new lists, without number limit, although each created list must belong to one of the two permitted types, either “**WHITE LIST**” or “**BLACK LIST**”, and can only generate one or more of the three types of actions contemplated.

List creation example:

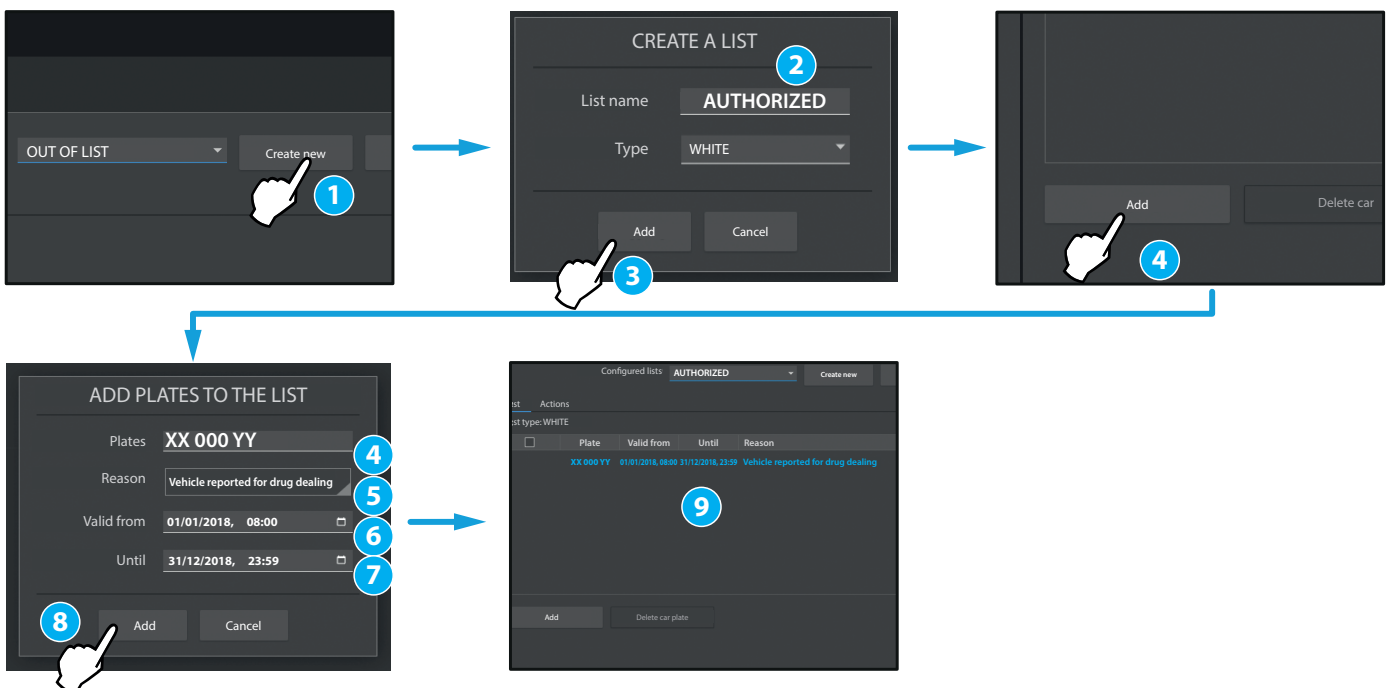

To delete a number plate, insert a “flag” on its side and click “delete” underneath.

To delete a list, select the list and click delete at the side.

## FTP list synchronisation

By enabling and then configuring the various parameters on this screen, it is possible to synchronise the various lists with a remote disk via FTP.

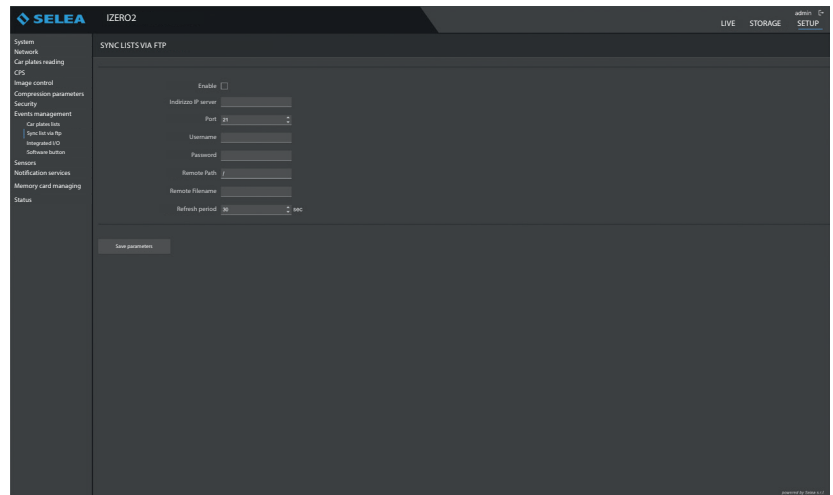

## Integrated I/O

It can be used to configure the behaviour of the two digital inputs of **iZero 2**, meaning which electric variation must be detected to generate a reason for an event. It is possible to decide if the event must start on completion of the variation (level) or while the variation is being performed (front). To make things easier, **iZero 2** shows a drawing that indicates with a red dash which electric phenomenon will be the triggering event. Also in this screen, and solely to make things easier, we have included the behaviour that the digital output will need to maintain when used as response action to an "event".

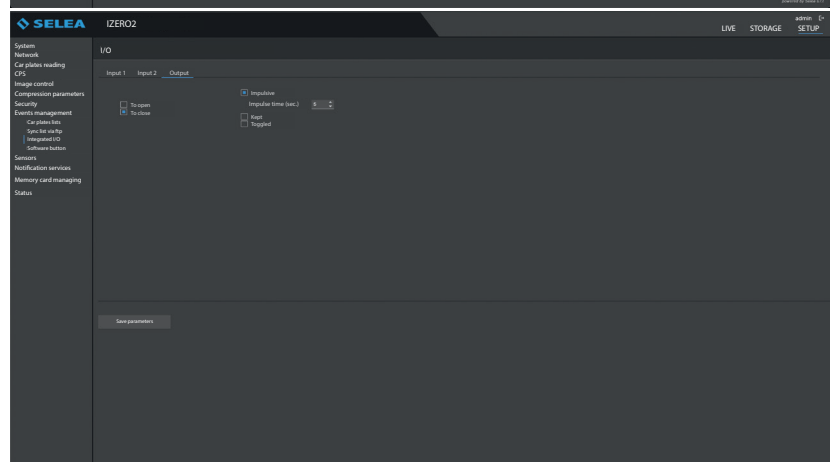
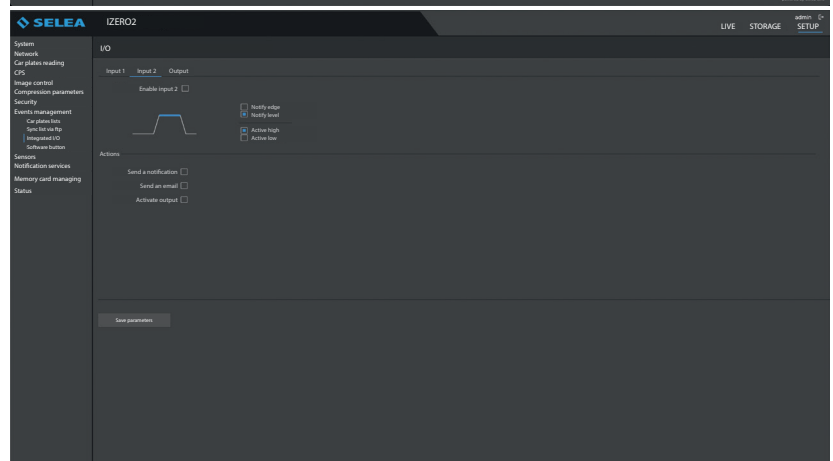
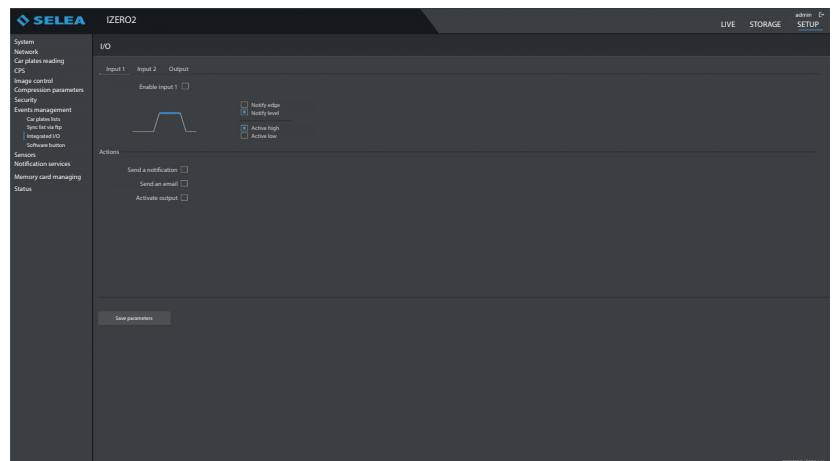

### Software button

It creates a **"button"** in the **home-page** of **iZero 2**, which when pressed generates an **"event"** (to which it will be possible to associate one or more actions, such as the manual opening of the bar). A name may be assigned to the button in the field below.

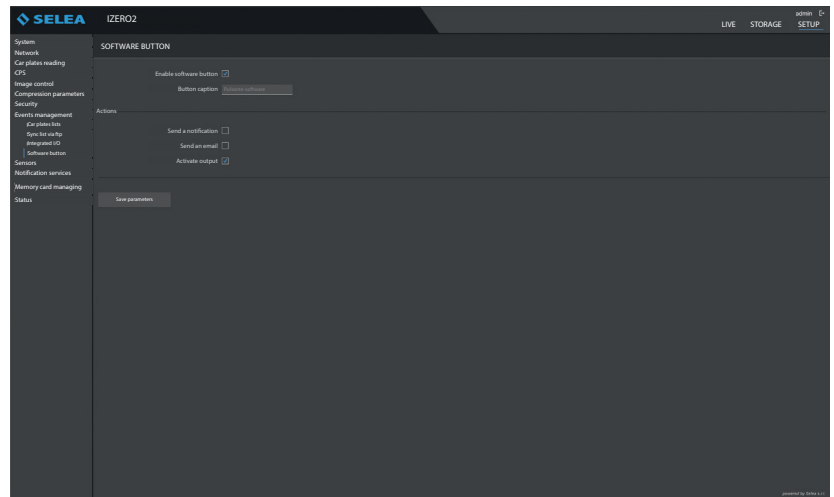

## SENSORS

### General

Air quality control can be enabled from here.

- A** Allows you to enable the air quality sensor, if installed on the camera.
- B** Shows the **sensor status**:
  - **OK**: the sensor is enabled.
  - **Disabled**: the sensor is disabled.
  - **Not found**: sensor not installed.
- C** Shows the state of the sensor and the PM10 and PM2.5 ( $\mu\text{g}/\text{m}^3$ ) values detected on the last reading.

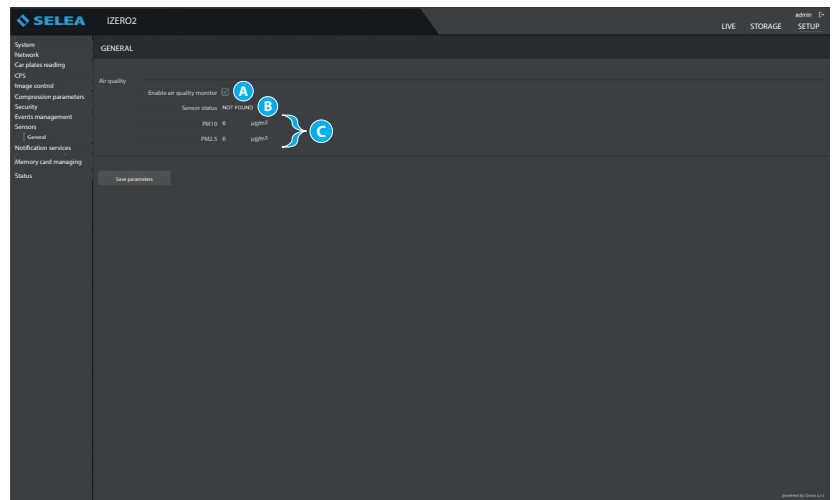

Third party software can extract the values read by the sensor using the following HTTP GET call: **<https://IPcamera/cgi-bin/pollution.php>** which will return a JSON with the sensor information as in the following example  
`{"status": "OK", "PM10": 4, "PM2_5": 3}`.

## NOTIFICATION SERVICES

It can be used to configure communication channels that will later be used in “**actions**” (such as the forwarding of mails, the FTP user, etc.). These channels are generally employed to send notifications. It is also possible to set the characteristics of such notifications.

### General

- A** Adjust the resolution of the images of the number plate sensor.
- B** Adjust the quality of the images of the number plate sensor.
- C** It automatically detects and obscures all elements in the frame, such as vehicles and people, that are not directly related to the vehicle whose number plate has been read.
- D** Choice of the information that will be sent for each type of sensor, to enable or disable the information select the box below.
- E** If selected, notifies only the plates with recognized nationality.
- F** Any information not sent through the network will be saved in the iZero 2 internal memory.
- G** It allows to select the notification mode for Arabic number plates with dual representation (Arabic and Latin). The camera reads both the Arabic and the Latin components. This function gives the possibility to decide whether to transmit both readings or only one of them, whether to keep them together or separate.

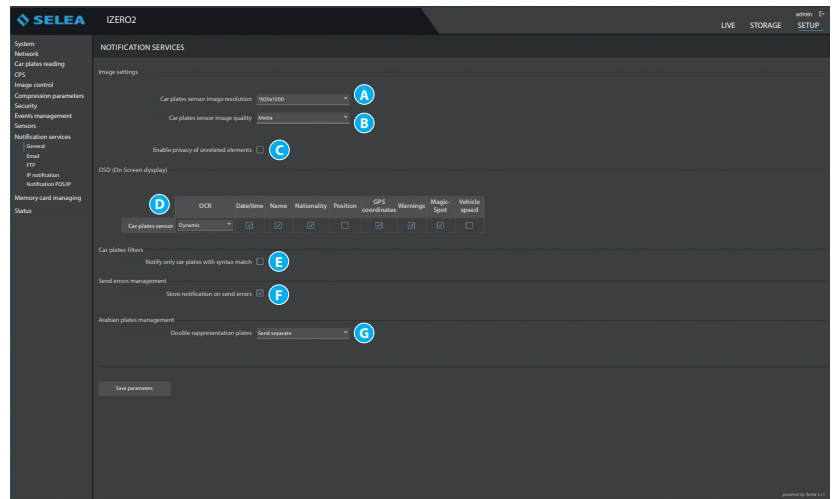

### Email

Enter here the parameters required for sending mails: **SMTP** server **IP/name** and credentials required for its use.

**iZero 2** will automatically fill the “**sender**” with the name assigned in the “**SYSTEM**” page, leaving to the user the possibility of customising the domain.

In this screen, it will also be necessary to indicate up to **4** mail recipients, which will be the ones receiving the notification when an event to which the mail has been assigned as consequential action is detected.

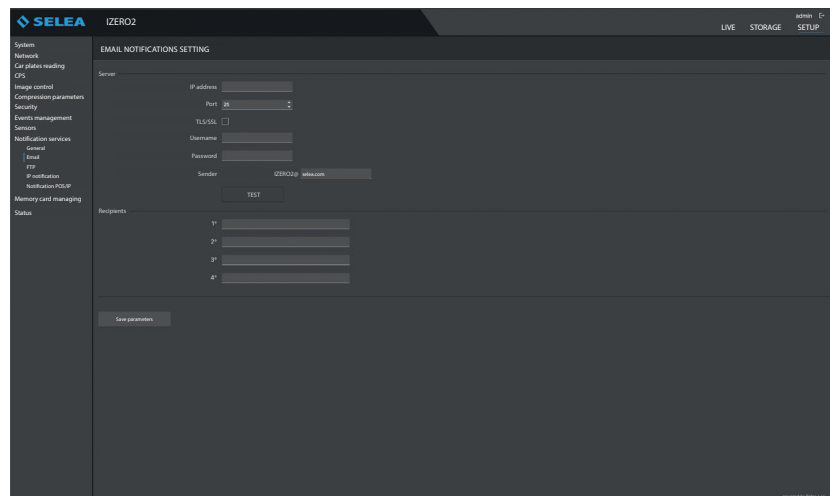

### FTP

In **iZero 2** it is possible to configure two servers (“**Server A**” and “**Server B**” page). For each server, enter the **IP** address of the machine on which the **FTP** server service is active, and to which **iZero 2** will send the snapshot, together with the corresponding port (if the standard port is already being used by other software installed). The authentication credentials must be the same as those that will have to then be entered in the **FTP** user that will be created on the **FTP** server (for example **Selea CPS**).

### Forwarding options:

“**Connection Method**”: it can have 3 different values:

**Standard**: standard non-protected FTP mode.

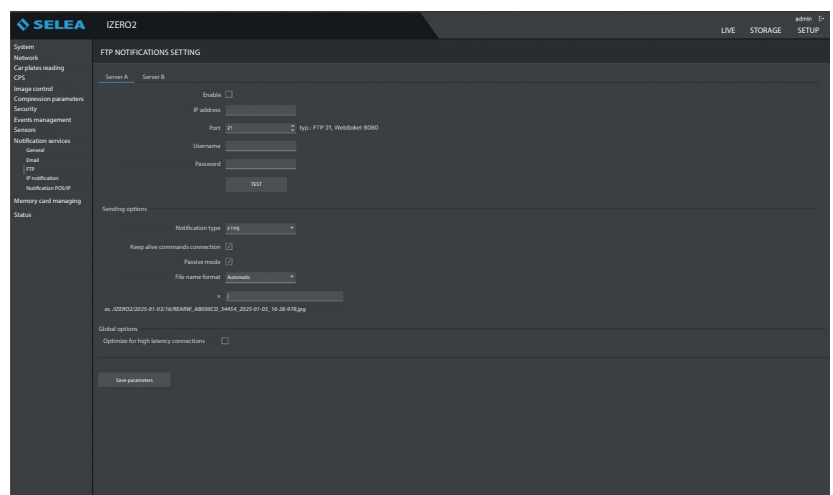



**FTPS:** image forwarding mode protected by “Explicit TLS” system.

**WebSocket CPS:** proprietary transmission mode in which images are forwarded through a secure HTTPS connection. The socket is open and indefinitely maintained. This type of communication avoids the need to manage more than one configuration of ports on firewalls, as only one port is open.

**“Keep the command connection active”:** it prevents the FTP server from terminating the connection after the snapshot has been received, asking that the login initially completed by the camera is kept active, so that less operations may be required at the next forwarding. This function is fully supported by Selea CPS (with several other FTP servers the communication will be interrupted after some time).

**“Passive mode”:** to enable passive connection mode.

**“Active mode data port”:** enter the connection port for active mode.

**“File name format”:** it entails an automatic system for allocating names to snapshots, or for the customisation of the path and name of the same through the use of TAGS (which can be selected using the appropriate key on the right of the field).

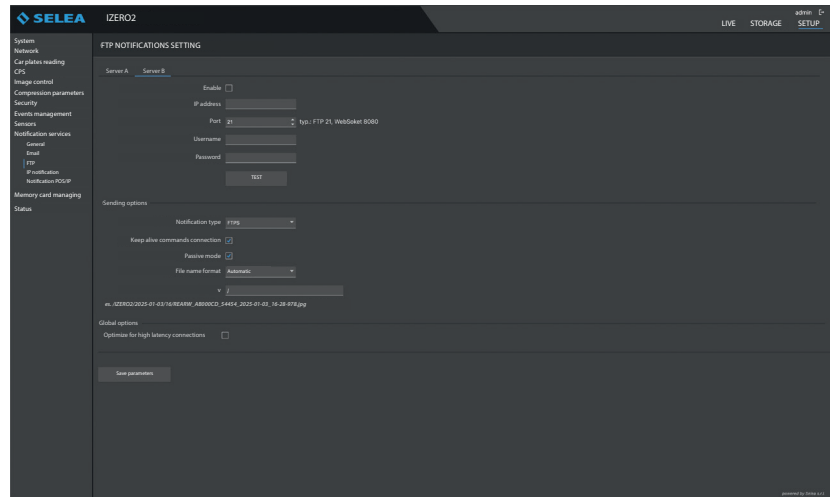

**IP notification**

Alarm notifications are forwarded to the **IP** that the user enters in the appropriate field, using one of the available protocols. It is possible to notify two servers at the same time (**ServerA** and **ServerB**).

**HTTP GET/POST:** Targa sends requests to the CGI web server in the typical formats of the selected protocol (GET or POST from the drop-down menu).

**TCP/IP:** Targa establishes a connection with the indicated IP. As soon as the connection is established, it forwards data based on the model in the field on the right.

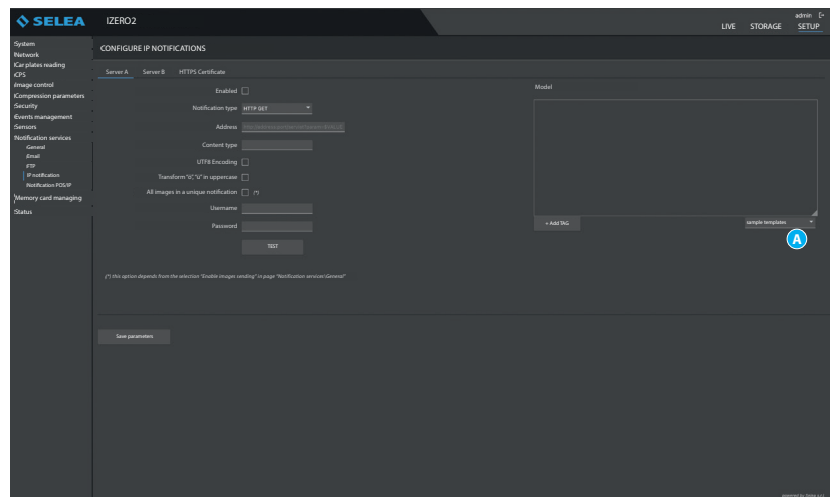

By pressing **“A”** shown in the figure below, it is possible to pre-load standard models that are valid for most situations. In case of needs, by pressing the appropriate key on the page it will be possible to add further **TAGS**.

In the example in the figure, the address could be a possible server listening on port **80**.

[http://192.168.1.120:80/notifica.cgi?param=\\$VALUES](http://192.168.1.120:80/notifica.cgi?param=$VALUES)

IP address      port      service name on web server      placeholder parameter

The **\$VALUES** placeholder will be replaced with the text in the field on the right, which can be fully customised based on the needs of the interaction software.

It must be noted that the text entered in the **“model”** field is forwarded in **ASCII** format. If necessary, it is also possible to forward **UTF8** coded text by ticking the appropriate **“flag”**.

**HTTPS certificate:** allows you to upload the https certificate of the reference server; in this case, the connection will take place only after verifying the identity of the server by comparing the declared certificate and the one inserted in the camera.

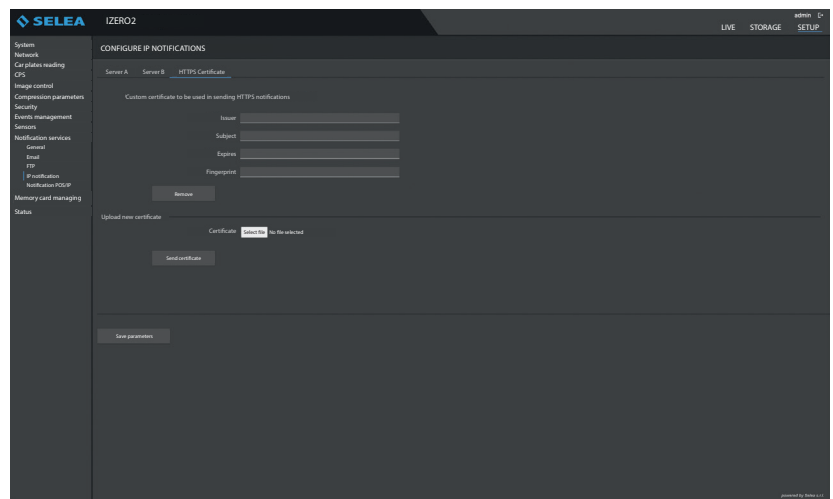

### POS/IP notification

This is a data and/or image transmission system (based on the placeholders used as models) compatible with several types of third-party VMS software, such as Milestone or Avigilon. It can be customised by the customer using the own management software based on communication requirements.

**“Enable”:** to enable or disable this type of communication.

**“Port”:** to specify the number of the port being used.

**“Permitted IP Accesses (1 to 4)”:** to be filled with the IP addresses of the clients that can access this “server” function offered by the camera.

**“MODEL”:** it contains the various TAGS relating to the possible information forwarded by the camera to the enabled IP addresses. This Model can be customised by the user using the list of all possible data fields available in the camera.

Press **“A”** to open a drop-down menu for access to a list of available pre-configured templates

**“Add TAG”:** it can be used to create an own custom model by entering the various **TAGS** required for the specific application.

**“Save Parameters”:** to save the **“POS/IP”** configuration and make it permanent.

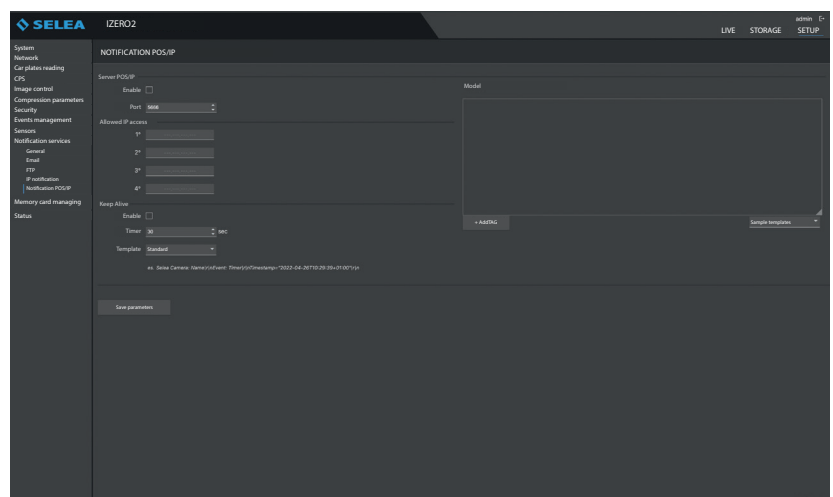

## MEMORY

### General

This is a graphic and intuitive representation of the memory available for snapshots, lists etc.

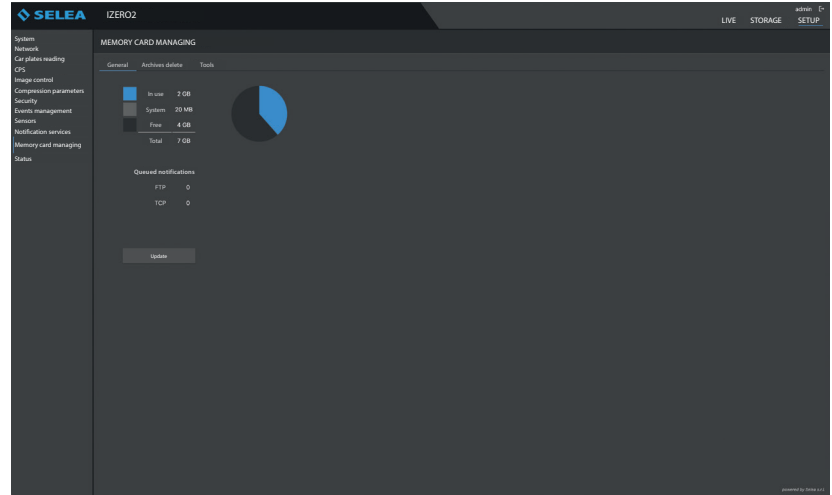

### Delete

The **“Delete”** sub-page can be used to set for how many days the saved information must be kept. All the saved information stored for a number of days exceeding the set limit will be deleted.

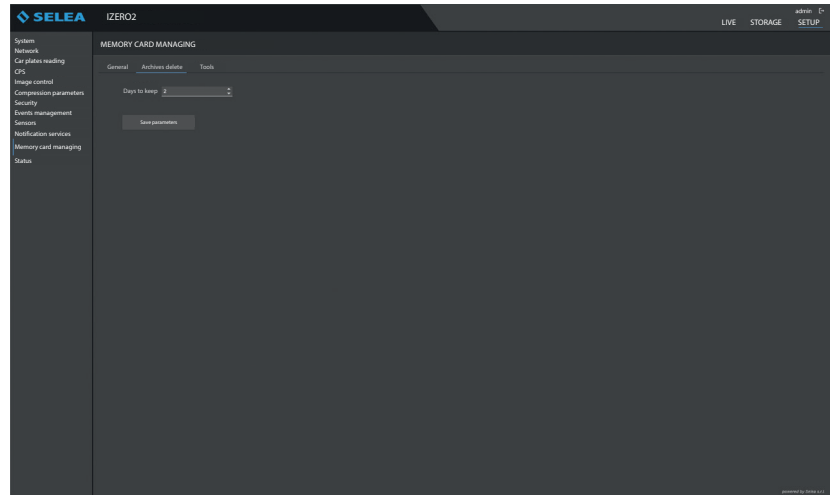

### Tools

The **“Tools”** sub-page contains the buttons to correctly remove the memory device without the risk of losing data (**“Prepare removal”** key), to simulate its absence (and therefore prevent the possibility of its use without physically accessing the inside of the camera enclosure), and to format it (**“Format”** key), to completely remove its content or correct any logic errors caused, for example, by blackouts during writing.

Furthermore, it is possible to make the data contained in the memory more secure by encrypting the data (**“Encrypt”** key).

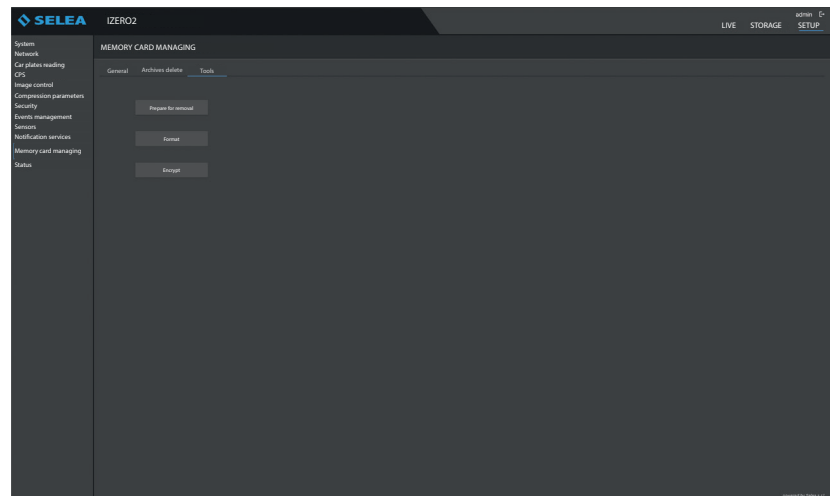

## STATUS

### General

It groups together information regarding the current camera operation (how long it has been on, processor temperature, operating temperature inside the camera enclosure, processor speed, CPS status, **IP** address and if an **FTP** connection with a server is active, etc.), and gives the possibility of rebooting the same through the “Tools” sub-page.

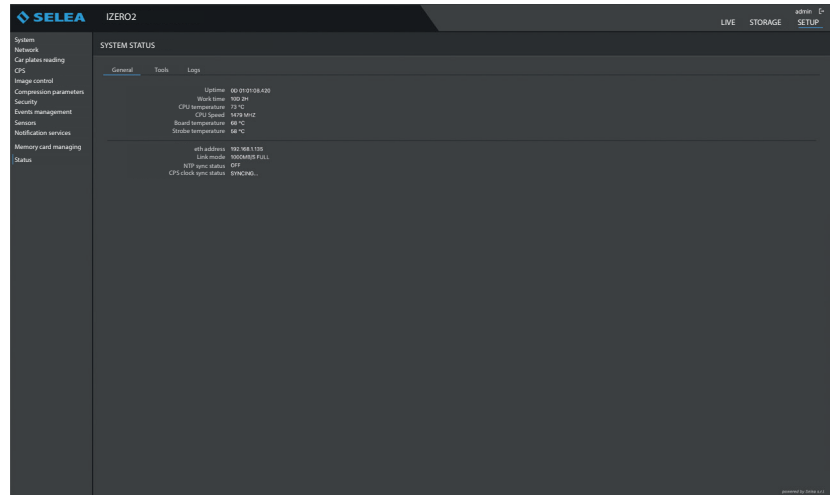

### Tools

In the “Tools” screen, the “Remote Address check” item gives the possibility of checking the consistency of the communication between the camera and an external service (e.g. NPT server, HTTP server, FTP server, email server, etc.).

The “Reboot” button can be used to restart the camera, while “Factory reset” resets the camera to the factory settings.

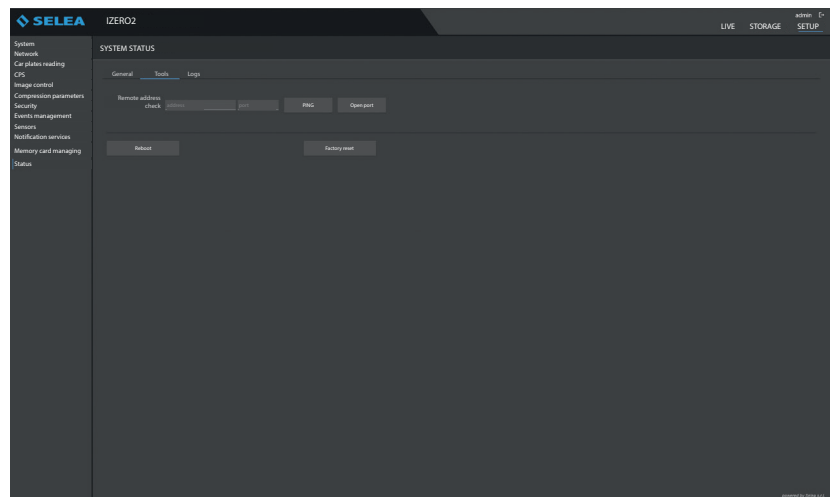

### Logs

In the “Logs” screen press “start” to see in real time the **Log** of all the camera internal operations relating to **CPS** and **System** services.

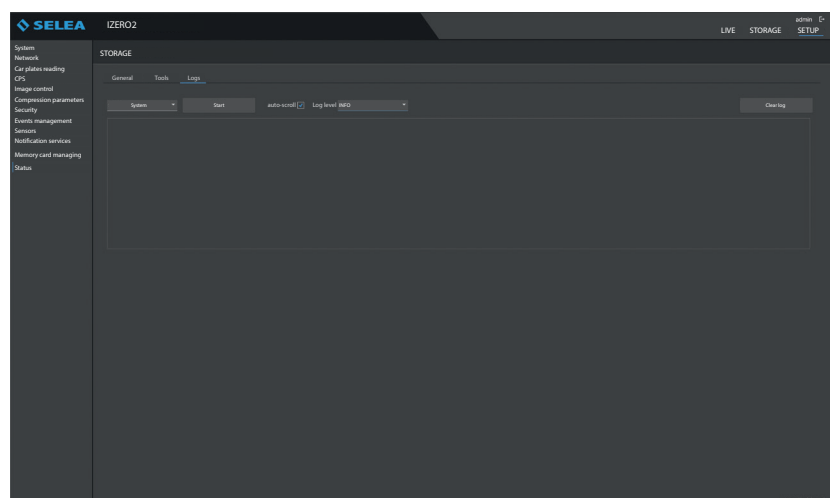

**AFTER A PERIOD OF INACTIVITY (EXCEEDING ONE WEEK), REMEMBER TO SYNCHRONISE THE CLOCK OF iZero 2 WITH THE COMPUTER!!** Otherwise the snapshots will be included in the database with wrong dates, causing issues during consultation.

# FIRMWARE UPDATE USING SELEATOOL

The **“firmware”** is the software installed in the camera internal memory that manages most of the **iZero 2** functions. The camera is already supplied with a pre-loaded firmware, which should not be modified unless:

- recommended by **Selea Customer Support**, when contacted by yourself due to technical issues.
- Selea has issued a new firmware version compatible with your model, which includes new interesting features.

**WARNING: Updating the firmware is a very delicate operation that should only be carried out if strictly necessary. Wrong firmware updates can make the product unusable, which must then be sent to a Selea Technical Support Centre for repairs.**

Make sure that during the firmware update there are no interruptions of any kinds.

If possible, when updating the firmware connect both the camera and the computer using an **UPS** protected electric line. Disable all screen savers and energy saving functions in the computer.

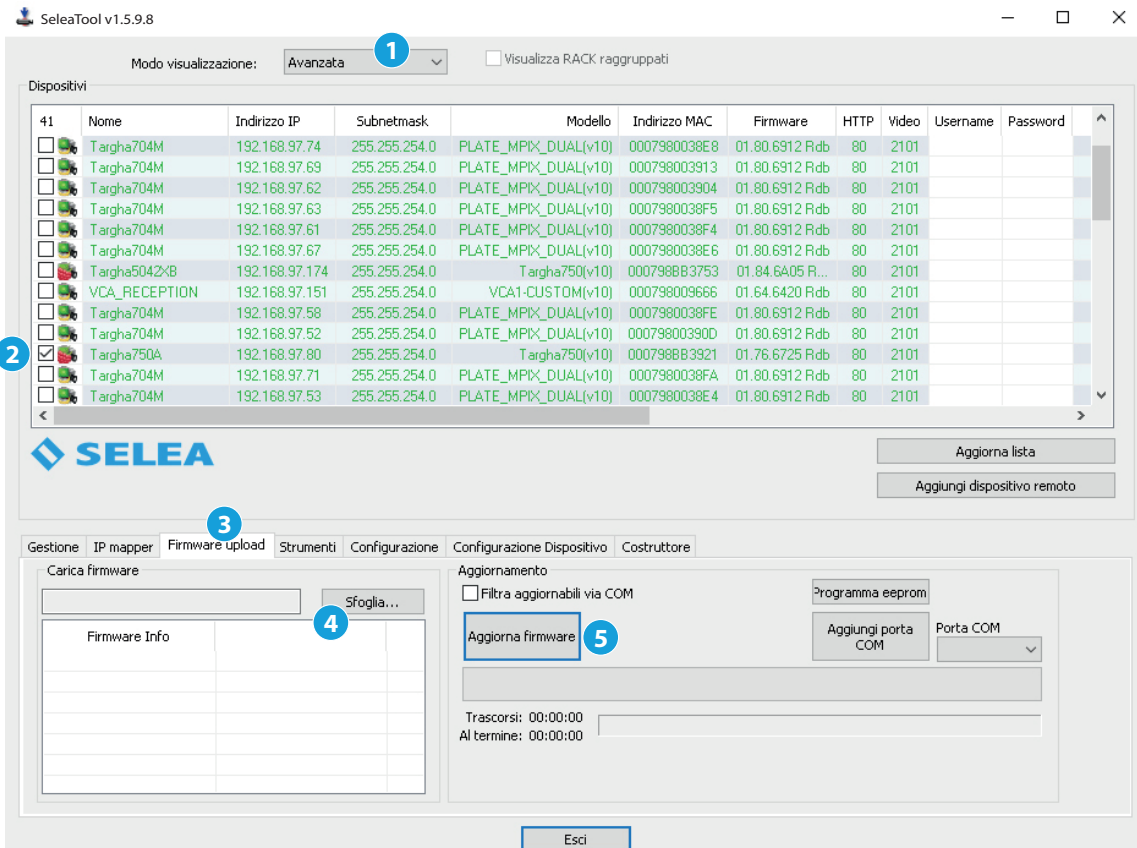

Before the starting the firmware update, make sure to have available all the files (.IMG extension) of the desired version, which can be downloaded from the [support.selea.com](http://support.selea.com) website, or obtained from **Selea Customer Support**.

The uploading of new firmware to the device must be completed through an **Ethernet** connection and using the **SeleaTool** wizard.

Follow the procedure below:

1. Open **SeleaTool**. Wait for the **“Selea Devices”** panel to list all the cameras of the network. Select **“Advanced”** display mode in the top drop-down menu.
2. Tick the box of the device to update.
3. In the **“Firmware upload”** page, click **“Browse”** and find the previously obtained firmware update file. Click **“Open”**.
4. The **“Firmware Info”** table on the bottom left shows information regarding the selected firmware. Check the compatibility with the model being updated and that the version is as desired.
5. It is now possible to proceed with the update: click **“Update firmware”**. **NOTE:** based on the access settings on the device to be updated, **iZero 2** authentication credentials must be entered in the appropriate fields on the same line as the product to be updated.
6. The **“Status”** panel bar and the **“Update”** column show the status of the update (deletion, upload, verification, ...) and the percentage advancement status.
7. After completing the installation, **iZero 2** restarts automatically and appears in the **SeleaTool** window. The restart confirmation message also appears. Click **“OK”**.

**NOTE: The update of the firmware does NOT cause the loss of any existing camera configurations. No changes are made to the IP address or to all the other set parameters.**

## CLEANING THE CAMERA

Once the camera has been unpacked and positioned, it may require cleaning.



**During cleaning activities only use a damp cloth. Do not use solvents or abrasive and non-abrasive products that could damage surfaces or components.**

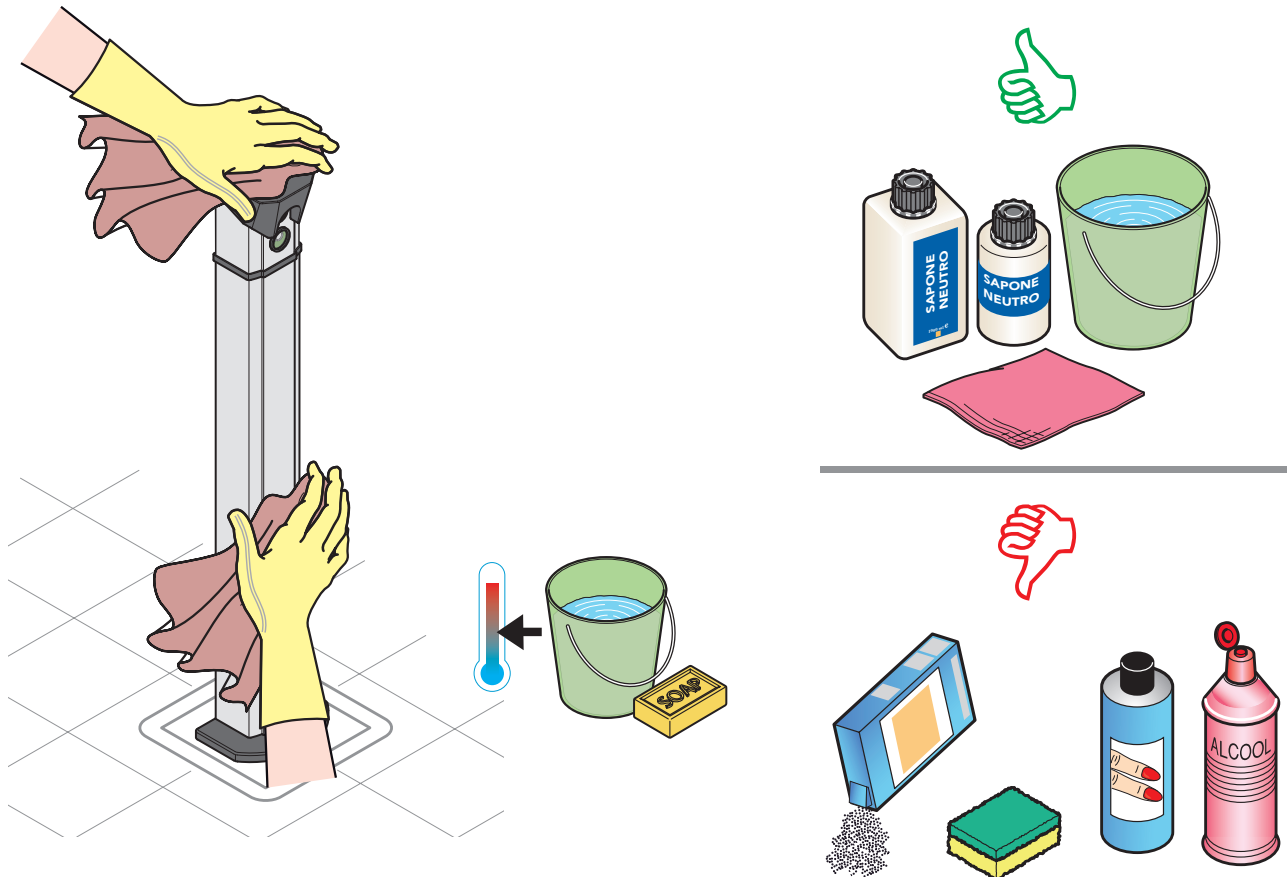

## MAINTENANCE

The **iZero 2** camera does not require any special routine maintenance: only external cleaning of the column and the outer lens glasses is necessary.



**During cleaning activities only use a damp cloth. Do not use solvents or abrasive and non-abrasive products that could damage surfaces or components.**



**Extraordinary maintenance activities must only be carried out by qualified personnel, authorised by the Distributor or Manufacturer.**



**Any type of intervention on the camera not authorised by the manufacturer will immediately invalidate the warranty.**



**It is absolutely forbidden to make any changes to the column and the internal parts of the camera. Any such changes will immediately invalidate the warranty.**

# DECLARATION OF CONFORMITY



## DECLARATION OF CONFORMITY



**SELEA Srl** with headquarters in  
Via Aldo Moro 69 - 46019 Cicognara di Viadana (MN) - Italy

### DECLARES

under its own responsibility that its number plate reading products of the Targa,iZero series  
comply with the requirements of the following directives:

#### **1) Directive on electromagnetic compatibility 2014/30/UE**

- EN 55032 Devices for multimedia technology Features of radio interference
- EN 55035 Devices for multimedia technology Characteristics of immunity.
- EN 61000 Electromagnetic Compatibility (harmonics emitted, flicker, electrostatic discharge, Immunity to radiated radio frequencies, immunity to fast transients, surge tests, conducted interference, Immunity to magnetic fields, immunity to fast interruptions and voltage variations)

#### **2) Low voltage directive 2014/35/EU**

- EN 62368-1:2018 / EN 62368-1:2020 (Rev. 3) Inform. technology equip., Equipment security.
- EN 62471:2008 Photobiological Safety (Risk-free group).
- EN 60529 Degree of protection provided by enclosures: (IP 66).
- EN 60068 Resistance in severe environmental conditions (dry heat, wet heat, cold).
- EN 60721 Resistance to Sinusoidal vibrations (Class 3M3).

#### **3) European 2011/65/EU and 2015/863/EU on the limitation to the use of dangerous substances** within electrical and electronic equipment according to the quantities described

- Lead Pb content: < 0.1%;
- Cadmium Cd content: < 0.01%;
- Polybrominated Biphenyl PBB Content <0.1%;
- Mercury Hg content: < 0.1%;
- Chromium Cr content: < 0.1%;
- Polybrominated Diphenyl Ethers PBDE content <0.1%;
- Bis(2Ethylhexyl) Phtalate DEHP content <0.1%;
- Benzil Buthyl Phtalate BBP content <0.1%;
- Dibutyl Phtalate DBP content <0.1%;
- Diisobutyl Phtalate DBP content <0.1%;

The products of the families listed above are therefore compliant with the RoHS directives

Cicognara, 30 January 2024

Manager

*Renato Grassi (R&D director)*



SELEA Srl-Italy  
Via Aldo Moro 69  
46019 Cicognara (MN)  
Tel+39037589091  
Fax+39037589080

Tax code and VAT No.: 0181290202  
REA 19806 Mantova  
Website: [www.selea.com](http://www.selea.com)  
Email: [infocom@selea.com](mailto:infocom@selea.com)  
PEC: [selea@pec.selea.com](mailto:selea@pec.selea.com)



## NOTES BY THE INSTALLER

---

---

---

---

---

---

---

---

---

---

---

---

---

---

---

---

---

---

---

---

---

---

---

---

---

---

---

---

### ***Selea limited warranty declaration***

The warranty shall not apply for faults caused by:

- Unauthorised modification or improper use.
- Improper or inadequate product maintenance or wiring.
- Damage caused by external events such as lightning, electric line overvoltage and telephone line fault.
- Fall or improper transport procedures
- Use of inappropriate components or accessories, or components not supplied by Selea.
- Use outside the limits of the environmental conditions of use of the product.
- Improper installation or maintenance.

**Selea** guarantees the product, the accessories and the supplies against manufacturing defects for a period of one year from the date of purchase (the date of the sale document shall apply). In case of fault notification received by **Selea** within the terms of the warranty, the company shall undertake to repair or replace the defective products. Replacement products may be new or as new.

**Selea** does not guarantee uninterrupted product operation. Should **Selea** be unable to replace or repair the product, the cost of the product at distribution level shall be reimbursed.

**Selea** products may contain refurbished parts with performances similar to new components.

**Selea** shall not issue any expressed warranty, either in writing or verbal. Notwithstanding the provisions of current regulations, implicit sale, quality and specific use suitability guarantees are limited to the duration of this warranty.

Notwithstanding the provisions of current local regulations, the remedies contemplated by this warranty declaration are the only actions for the safeguard of the customer. Notwithstanding what expressly indicated above, and within the provisions of the law, **Selea** rejects all personal responsibility or all responsibility of its suppliers in connection with contract or tort (including negligence) for consequential, indirect, incidental, special or punitive damages of any nature whatsoever, or for loss of income or profit, loss of information or data, or other financial loss resulting or in connection with the sale, installation, maintenance, use, performance, failure or interruption of operation of its products. This shall also apply when **Selea** or the distributor are informed of the possibility of such damage. The responsibility of the company shall be limited to the repair or replacement of the product, or the reimbursement of the price paid, at the full discretion of **Selea**.





***Selea s.r.l.***

Via Aldo Moro n.69 - 46019 Cicognara (Mantova) - Italy - VAT No. 0181129020

Telephone +39 0375 889091

***[www.selea.com](http://www.selea.com) - [infocom@selea.com](mailto:infocom@selea.com)***